

**E d g e - c o r e E**

Powered by Accton

**ES4700 series  
Chassis Core Routing  
Switch**

[www.edge-core.com](http://www.edge-core.com)

## **Preface**

ES4700BD series switch is a high performance routing switch released by Edge-Core that can be deployed as the core layer device for campus and enterprise networks, or as an aggregation device for IP metropolitan area networks (MAN). ES4700BD series switch provides 4 and 10 slots , with support for various types of line cards and can seamlessly support a variety of network interfaces from 100Mb, 1000Mb to 10Gb Ethernet.

We are providing this manual for your better understanding, use and maintenance of the ES4700BD. We strongly recommend you to read through this manual carefully before installation and configuration to avoid possible malfunction or damage to the switch. Furthermore, we sincerely hope our products and services satisfy you.

## Compliances and Safety Warnings

### FCC - Class A

This equipment has been tested and found to comply with the limits for a Class A digital device, pursuant to part 15 of the FCC Rules. These limits are designed to provide reasonable protection against harmful interference when the equipment is operated in a commercial environment. This equipment generates, uses, and can radiate radio frequency energy and, if not installed and used in accordance with the instruction manual, may cause harmful interference to radio communications. Operation of this equipment in a residential area is likely to cause harmful interference in which case the user will be required to correct the interference at his own expense.

You are cautioned that changes or modifications not expressly approved by the party responsible for compliance could void your authority to operate the equipment.

You may use unshielded twisted-pair (UTP) for RJ-45 connections - Category 3 or better for 10 Mbps connections, Category 5 or better for 100 Mbps connections, Category 5, 5e, or 6 for 1000 Mbps connections. For fiber optic connections, you may use 50/125 or 62.5/ 125 micron multimode fiber or 9/125 micron single-mode fiber.

### Industry Canada - Class A

This digital apparatus does not exceed the Class A limits for radio noise emissions from digital apparatus as set out in the interference-causing equipment standard entitled “Digital Apparatus,” ICES-003 of the Department of Communications.

Cet appareil numérique respecte les limites de bruits radioélectriques applicables aux appareils numériques de Classe A prescrites dans la norme sur le matériel brouilleur: “Appareils Numériques,” NMB-003 édictée par le ministère des Communications.

### Japan VCCI Class A

この装置は、情報処理装置等電波障害自主規制協議会（VCCI）の基準に基づくクラスA情報技術装置です。この装置を家庭環境で使用すると電波妨害を引き起こすことがあります。この場合には使用者が適切な対策を講ずるよう要求されることがあります。

### CE Mark Declaration of Conformance for EMI and Safety (EEC)

This information technology equipment complies with the requirements of the Council Directive 89/336/EEC on the Approximation of the laws of the Member States relating to Electromagnetic Compatibility and 73/23/EEC for electrical equipment used within certain voltage limits and the Amendment Directive 93/68/EEC. For the evaluation of the compliance with these Directives, the following standards were applied:

- RFI Emission:
- Limit class A according to EN 55022:1998
  - Limit class A for harmonic current emission according to EN 61000-3-2/1995
  - Limitation of voltage fluctuation and flicker in low-voltage supply system according to EN 61000-3-3/1995
- Immunity:
- Product family standard according to EN 55024:1998
  - Electrostatic Discharge according to EN 61000-4-2:1995 (Contact Discharge:  $\pm 4$  kV, Air Discharge:  $\pm 8$  kV)
  - Radio-frequency electromagnetic field according to EN 61000-4-3:1996 (80 - 1000 MHz with 1 kHz AM 80% Modulation: 3 V/m)
  - Electrical fast transient/burst according to EN 61000-4-4:1995 (AC/DC power supply:  $\pm 1$  kV, Data/Signal lines:  $\pm 0.5$  kV)
  - Surge immunity test according to EN 61000-4-5:1995 (AC/DC Line to Line:  $\pm 1$  kV, AC/DC Line to Earth:  $\pm 2$  kV)
  - Immunity to conducted disturbances, Induced by radio-frequency fields: EN 61000-4-6:1996 (0.15 - 80 MHz with 1 kHz AM 80% Modulation: 3 V/m)
  - Power frequency magnetic field immunity test according to EN 61000-4-8:1993 (1 A/m at frequency 50 Hz)
  - Voltage dips, short interruptions and voltage variations immunity test according to EN 61000-4-11:1994 (>95% Reduction @10 ms, 30% Reduction @500 ms, >95% Reduction @5000 ms)
- LVD:
- EN 60950 (A1/1992; A2/1993; A3/1993; A4/1995; A11/1997)

**Caution: Do not plug a phone jack connector in the RJ-45 port. This may damage this device. Les raccordeurs ne sont pas utilisés pour le système téléphonique!**

## Safety Compliance

### Warning: Fiber Optic Port Safety



When using a fiber optic port, never look at the transmit laser while it is powered on. Also, never look directly at the fiber TX port and fiber cable ends when they are powered on.

### Avertissement: Ports pour fibres optiques - sécurité sur le plan optique



Ne regardez jamais le laser tant qu'il est sous tension. Ne regardez jamais directement le port TX (Transmission) à fibres optiques et les embouts de câbles à fibres optiques tant qu'ils sont sous tension.

### Warnhinweis: Faseroptikanschlüsse - Optische Sicherheit



Niemals ein Übertragungslaser betrachten, während dieses eingeschaltet ist. Niemals direkt auf den Faser-TX-Anschluß und auf die Faserkabelenden schauen, während diese eingeschaltet sind.

## Please read the following safety information carefully before

### installing the switch:

**WARNING:** Installation and removal of the unit must be carried out by qualified personnel only.

- The unit must be connected to an earthed (grounded) outlet to comply with international safety standards.
- Do not connect the unit to an A.C. outlet (power supply) without an earth (ground) connection.
- The appliance coupler (the connector to the unit and not the wall plug) must have a configuration for mating with an EN 60320/IEC 320 appliance inlet.
- The socket outlet must be near to the unit and easily accessible. You can only remove power from the unit by disconnecting the power cord from the outlet.
- This unit operates under SELV (Safety Extra Low Voltage) conditions according to IEC 60950. The conditions are only maintained if the equipment to which it is connected also operates under SELV conditions.

*France and Peru only*

This unit cannot be powered from IT† supplies. If your supplies are of IT type, this unit must be powered by 230 V (2P+T) via an isolation transformer ratio 1:1, with the secondary connection point labelled Neutral, connected directly to earth (ground).

† Impédance à la terre

Power Cord Set	
U.S.A. and Canada	The cord set must be UL-approved and CSA certified.
	The minimum specifications for the flexible cord are: - No. 18 AWG - not longer than 2 meters, or 16 AWG. - Type SV or SJ - 3-conductor
	The cord set must have a rated current capacity of at least 10 A
	The attachment plug must be an earth-grounding type with NEMA 5-15P (15 A, 125 V) or NEMA 6-15P (15 A, 250 V) configuration.
Denmark	The supply plug must comply with Section 107-2-D1, Standard DK2-1a or DK2-5a.
Switzerland	The supply plug must comply with SEV/ASE 1011.
U.K.	The supply plug must comply with BS1363 (3-pin 13 A) and be fitted with a 5 A fuse which complies with BS1362.
	The mains cord must be <HAR> or <BASEC> marked and be of type HO3VVF3GO.75 (minimum).
Europe	The supply plug must comply with CEE7/7 ("SCHUKO").
	The mains cord must be <HAR> or <BASEC> marked and be of type HO3VVF3GO.75 (minimum).
	IEC-320 receptacle.

**Veillez lire à fond l'information de la sécurité suivante avant d'installer le Switch:**

**AVERTISSEMENT:** L'installation et la dépose de ce groupe doivent être confiés à un personnel qualifié.

- Ne branchez pas votre appareil sur une prise secteur (alimentation électrique) lorsqu'il n'y a pas de connexion de mise à la terre (mise à la masse).
- Vous devez raccorder ce groupe à une sortie mise à la terre (mise à la masse) afin de respecter les normes internationales de sécurité.

- Le coupleur d'appareil (le connecteur du groupe et non pas la prise murale) doit respecter une configuration qui permet un branchement sur une entrée d'appareil EN 60320/IEC 320.
- La prise secteur doit se trouver à proximité de l'appareil et son accès doit être facile. Vous ne pouvez mettre l'appareil hors circuit qu'en débranchant son cordon électrique au niveau de cette prise.
- L'appareil fonctionne à une tension extrêmement basse de sécurité qui est conforme à la norme IEC 60950. Ces conditions ne sont maintenues que si l'équipement auquel il est raccordé fonctionne dans les mêmes conditions.

*France et Pérou uniquement:*

Ce groupe ne peut pas être alimenté par un dispositif à impédance à la terre. Si vos alimentations sont du type impédance à la terre, ce groupe doit être alimenté par une tension de 230 V (2 P+T) par le biais d'un transformateur d'isolement à rapport 1:1, avec un point secondaire de connexion portant l'appellation Neutre et avec raccordement direct à la terre (masse).

<b>Cordon électrique - Il doit être agréé dans le pays d'utilisation</b>	
Etats-Unis et Canada:	Le cordon doit avoir reçu l'homologation des UL et un certificat de la CSA. Les spécifications minimales pour un câble flexible sont AWG No. 18, ou AWG No. 16 pour un câble de longueur inférieure à 2 mètres. - type SV ou SJ - 3 conducteurs Le cordon doit être en mesure d'acheminer un courant nominal d'au moins 10 A. La prise femelle de branchement doit être du type à mise à la terre (mise à la masse) et respecter la configuration NEMA 5-15P (15 A, 125 V) ou NEMA 6-15P (15 A, 250 V).
Danemark :	La prise mâle d'alimentation doit respecter la section 107-2 D1 de la norme DK2 1a ou DK2 5a.
Suisse:	La prise mâle d'alimentation doit respecter la norme SEV/ASE 1011.
Europe	La prise secteur doit être conforme aux normes CEE 7/7 ("SCHUKO") Le cordon secteur doit porter la mention <HAR> ou <BASEC> et doit être de type HO3VVF3GO.75 (minimum).

**Bitte unbedingt vor dem Einbauen des Switches die folgenden Sicherheitsanweisungen durchlesen:**

- WARNUNG:** Die Installation und der Ausbau des Geräts darf nur durch Fachpersonal erfolgen.
- Das Gerät sollte nicht an eine ungeerdete Wechselstromsteckdose angeschlossen werden.
  - Das Gerät muß an eine geerdete Steckdose angeschlossen werden, welche die internationalen Sicherheitsnormen erfüllt.
  - Der Gerätestecker (der Anschluß an das Gerät, nicht der Wandsteckdosenstecker) muß einen gemäß EN 60320/IEC 320 konfigurierten Geräteeingang haben.
  - Die Netzsteckdose muß in der Nähe des Geräts und leicht zugänglich sein. Die Stromversorgung des Geräts kann nur durch Herausziehen des Gerätenetzkabels aus der Netzsteckdose unterbrochen werden.
  - Der Betrieb dieses Geräts erfolgt unter den SELV-Bedingungen (Sicherheitskleinstspannung) gemäß IEC 60950. Diese Bedingungen sind nur gegeben, wenn auch die an das Gerät angeschlossenen Geräte unter SELV-Bedingungen betrieben werden.

<b>Stromkabel. Dies muss von dem Land, in dem es benutzt wird geprüft werden:</b>	
Schweiz	Dieser Stromstecker muß die SEV/ASE 1011 Bestimmungen einhalten.
Europe	Das Netzkabel muß vom Typ HO3VVF3GO.75 (Mindestanforderung) sein und die Aufschrift <HAR> oder <BASEC> tragen. Der Netzstecker muß die Norm CEE 7/7 erfüllen ("SCHUKO").

### **Warnings and Cautionary Messages**

**Warning:** This product does not contain any serviceable user parts.

**Warning:** Installation and removal of the unit must be carried out by qualified personnel only.

**Warning:** When connecting this device to a power outlet, connect the field ground lead on the tri-pole power plug to a valid earth ground line to prevent electrical hazards.

**Warning:** This switch uses lasers to transmit signals over fiber optic cable. The lasers are compliant with the requirements of a Class 1 Laser Product and are inherently eye safe in normal operation. However, you should never look directly at a transmit port when it is powered on.

**Caution:** Do not plug a phone jack connector in the RJ-45 port. This may damage this device. Les raccordeurs ne sont pas utilisé pour le système téléphonique!

**Caution:** Use only twisted-pair cables with RJ-45 connectors that conform to FCC standards.

**Caution:** Wear an anti-static wrist strap or take other suitable measures to prevent electrostatic discharge when handling this equipment.

## Environmental Statement

The manufacturer of this product endeavours to sustain an environmentally-friendly policy throughout the entire production process. This is achieved through the following means:

- Adherence to national legislation and regulations on environmental production standards.
- Conservation of operational resources.
- Waste reduction and safe disposal of all harmful un-recyclable by-products.
- Recycling of all reusable waste content.
- Design of products to maximize recyclables at the end of the product's life span.
- Continual monitoring of safety standards.

### End of Product Life Span

This product is manufactured in such a way as to allow for the recovery and disposal of all included electrical components once the product has reached the end of its life.

### Manufacturing Materials

There are no hazardous nor ozone-depleting materials in this product.

### Documentation

All printed documentation for this product uses biodegradable paper that originates from sustained and managed forests. The inks used in the printing process are non-toxic.

## Purpose

This guide details the hardware features of the switch, including its physical and performance-related characteristics, and how to install the switch.

## Related Publications

The following publication gives specific information on how to operate and use the management functions of the switches:

*The Gigabit Ethernet Switch Management Guide*

Also, as part of both switches' firmware, there is an online web-based help that describes all management related features.



# Content

<b>Preface .....</b>	<b>ii</b>
<b>Content.....</b>	<b>ix</b>
<b>Chapter 1 Product Overview .....</b>	<b>1</b>
<b>1.1 Product Brief.....</b>	<b>1</b>
1.1.1 Introduction.....	2
1.1.2 Features.....	2
1.1.3 Main Features.....	5
<b>1.2 Technical specifications.....</b>	<b>5</b>
<b>1.3 Physical Specifications.....</b>	<b>6</b>
<b>1.4 Hardware Components.....</b>	<b>6</b>
1.4.1 Chassis .....	6
1.4.2 Introduction to ES4700BD cards .....	11
1.4.3 Power supply .....	33
1.4.4 Power Distribution Box .....	36
1.4.5 System Backplane .....	37
1.4.6 Fan Tray .....	38
1.4.7 Dust Gauze .....	39
1.4.8 Rear Panel .....	40
1.4.9 Side Panels.....	42
<b>1.5 System Features .....</b>	<b>44</b>
1.5.1 ES4704BD System Features .....	44
1.5.2 ES4710BD System Features .....	45
<b>Chapter 2 Hardware Installation.....</b>	<b>47</b>
<b>2.1 Basic Requirements .....</b>	<b>48</b>
2.1.1 Site Requirements .....	48
2.1.2 Temperature and Humidity Requirements .....	49
2.1.3 Dust and Particles.....	49
2.1.4 Preventing Electrostatic Discharge Damage.....	50
2.1.5 Anti-interference Requirements.....	50
2.1.6 Rack Configuration.....	51
2.1.7 Power Supply Requirements .....	51
<b>2.2 Preparing for Installation .....</b>	<b>52</b>
2.2.1 Checking Switch Hardware Configuration and Accessories .....	52
2.2.2 Required Tools and Utilities.....	53
<b>2.3 Hardware Installation .....</b>	<b>53</b>
2.3.1 Switch Installation .....	54
2.3.2 Switch grounding.....	57
2.3.3 Card and module installation.....	58
2.3.4 Connecting to the console.....	65

2.3.5 SFP transceiver installation .....	65
2.3.6 XENPAK transceiver installation .....	66
2.3.7 Copper Cable/Fiber Cable Connection .....	66
2.3.8 Power supply connection .....	67
<b>Chapter 3 Caractéristiques du système ES4700BD .....</b>	<b>69</b>

---

# Chapter 1 Product Overview

**RECOMMENDATION:** Please read this manual first before using the switch, following the instructions to avoid damaging the device.

## 1.1 Product Brief



Fig 1-1 ES4704BD Switch



Fig 1-2 ES4710BD Switch

---

## 1.1.1 Introduction

Edge-Core ES4700BD is a high performance routing switch that can be deployed as a core layer device for campus and enterprise networks, or an aggregation device for IP metropolitan area networks (MAN).

ES4704BD provides 4 slots, 3 or 2 of which are interface module slots. ES4710BD provides 10 slots, 8 of which are interface module slots. ES4700BD supports various types of line cards, and can seamlessly support network interfaces from 100Mb, 1000Mb to 10Gb Ethernet. Featuring functions such as policy-based routing, IPv6, and load balance, it is capable of flexibly meeting the different requirements of complex customer environments. Furthermore, ES4700BD allows redundancy for management modules, power supply. It supports AC-input power supplies, with hot-swapping support for cards, power supplies and fans. The working temperature of all cards can be monitored in real-time, offering carrier-class reliability.

## 1.1.2 Features

### ■ Advanced Architecture

The design for the ES4700BD Series core routing switch is fully distributed architecture. With a powerful ASIC chip dedicated to high-speed route lookup and traffic forwarding through “longest-match” and “packet-by-packet” mode, the switch ensures enhanced forwarding performance and scalability. ES4700BD can effectively block network viruses such as “Code red”, “Worm.Blaster” and “Worm.Sasser” etc, and is a great choice for large scale networks with busy transactions and complex traffic, therefore meeting the metro-trend for Ethernet.

### ■ Interfaces

ES4704BD provides 4 slots, and can be configured in Primary controller-Primary Backup mode with 2 management modules and 2 network modules, or Single controller mode with 1 management module and 3 network modules.

ES4710BD provides 10 slots, and can be configured in Primary controller-Primary Backup mode with 2 management modules and 8 network modules, or Single controller mode with 1 management module and 8 network modules.

### ■ Carrier Class Reliability

To meet the strict requirements for device reliability of carrier class networks and to ensure 100% uptime of network cores, the design of ES4700BD enables redundancy for all critical parts, such as power supply, management modules and network links, all modules are also hot-swappable, and working temperatures of all parts are monitored real-time.

---

## ■ Support for 10G Ethernet

10Gb Ethernet (10GbE) is a leap of Ethernet in both speed and distance, in which full-duplex technology is employed, thus avoiding low-speed, half-duplex CSMA/CD protocol. Moreover, 10GbE maintains the essence of the original Ethernet model, therefore can integrate with the current Ethernet environment seamlessly. ES4700BD supports multi-port 10Gb fiber modules, providing wider bandwidth and more powerful processing capacity, therefore simplifying network structure and lowering network infrastructure cost. It is an ideal solution for MAN/WAN applications.

## ■ MAC Address Control

In addition to the standard MAC address dynamic learning, ES4700BD introduces several MAC table-based management functions. MAC address binding achieves secure access through the curb of connecting MAC address on the ports. The MAC filtering function can screen unauthorized access devices through MAC address filtering.

## ■ VLAN Configuration

ES4700BD support standard IEEE802.1Q VLAN, port-based VLAN and GVRP VLAN. IEEE802.1Q VLAN can divide ports into up to 4094 VLAN groups. When IEEE802.1Q VLAN tagging is used, cross-switch VLAN grouping can be enabled to manage broadcasting traffic, offer better security and improved network performance. GARP VLAN Registration Protocol (GVRP) based VLANs can achieve dynamic VLAN registration via GARP (Generic Attribute Registration Protocol), therefore a more flexible VLAN application results by reducing VLAN configurations due to less VLAN configuration changes.

## ■ Layer 3 Forwarding

Layer 3 forwarding is the forwarding of Layer 3 packets (IP packet) across VLANs, which ES4700BD uses switch chip hardware to forward IP packets, facilitating the on-chip host route entries and default routing table entries, allowing IP packets to be forwarded at full wire speed.

## ■ Layer 3 Routing Protocols

ES4700BD supports static routing (RIP, OSPF and BGP routing protocols) and Multicast Protocols (IGMP, IGMP Snooping, PIM-SM, PIM-DM and DVMRP), Policy Routing, IPv6, and Load Balance etc.

## ■ QoS

ES4700BD supports various QoS policies. It provides 8 priority queues for each port with bandwidth that can be individually set. WRR/SP/SWRR scheduling are also supported. Traffic can be sorted by ports, VLAN, DSCP, IP precedence and ACL, etc. By assigning different DSCP, IP priorities and bandwidth, different service quality for voice, data and video transmissions can be achieved.

## ■ ACL

ES4700BD supports standard and extended ACLs. ACL is an IP packets filtering mechanism employed by switches, providing network traffic control by granting or denying access through the switches, and thus effectively safeguarding the security of networks. ES4700BD can filter inbound IP-based traffic by source/destination IP/Mac addresses, IP protocol types, TCP/IP port numbers, IP Precedence and ToS information.

## ■ IEEE802.1x Access Authentication

ES4700BD supports port-based IEEE802.1x access authentication. Access

---

authentication can be managed by number of client per port and dynamic secure authentication based on MAC addresses..

### ■ **Spanning Tree**

ES4700BD provides support for IEEE 802.1D Spanning Tree Protocol (STP), IEEE 802.1w Rapid Spanning Tree Protocol (RSTP), and IEEE802.1s Multiple Spanning Tree Protocol (MSTP). Spanning-Tree Protocol is a link management protocol that provides path redundancy while preventing undesirable loops in the network.

### ■ **Bandwidth Management (Port bandwidth Limit)**

ES4700BD features upstream and downstream bandwidth management for both, enabling different access bandwidth to be specified according to user levels. Each port can be assigned with different bandwidth to meet the management demands of Access networks.

### ■ **Trunk Port**

Trunk port of IEEE802.3ad is supported by ES4700BD. A Trunk group of 2 to 8 ports can be established for link redundancy and load balance.

### ■ **IGMP Snooping**

ES4700BD supports IGMP Snooping based on multi-casting applications enabling various multi-cast services (e.g. multimedia playback, remote education and recreation) in an access network with lowered network traffic.

### ■ **Broadcast Storm Control**

ES4700BD can effectively prevent broadcast storms from wasting bandwidth with packet level Broadcast Storm Control function, resulting in improved overall system performance.

### ■ **Port Mirroring**

ES4700BD supports Port Mirroring, which is used to mirror the inbound and/or outbound traffic on specific port(s) to another port to gather related statistics, which is useful in troubleshooting and traffic monitoring.

### ■ **DHCP Server, Relay and Client**

ES4700BD supports a DHCP Server. It can dynamically assign IP addresses to hosts or MAC addresses, and specified IP addresses to implement MAC-IP binding.

### ■ **RADIUS**

ES4700BD supports RADIUS (Remote Dial-In User Service) authentication, enabling users to be authenticated via IEEE802.1x protocols.

### ■ **Comprehensive Network Management**

With ES4700BD, in-band and out-of-band management can be done through Console, Telnet and SNMP. Console and Telnet management provides simple and easy CLI (command line interface). SNMP management is V1 and V2C compliant, supporting Ether-Like MIB, Bridge MIB and MIB II, and RMON 1/2/3/9 MIB. With Edge-Core's ECview, full SNMP network management is available. Furthermore, ES4700BD provides a unique workstation IP setting management, enabling the switch to filter unauthorized remote network administrative connections, and keep the validity, security and consistency of remote network management.

---

## 1.1.3 Main Features

- ES4704BD 4 slots that can be configured in Primary controller-Primary Backup mode with 2 management modules and 2 network modules, or Single controller mode with one management module and 3 network modules.
- ES4710BD 10 slots that can be configured in Primary controller-Primary Backup mode with 2 management modules and 8 network modules, or Single controller mode with one management module and 8 network modules.
- Store-and-forward switching, ensuring minimal latency
- Auto MDI/MDI-X, enabled on all RJ-45 ports, allows connections to other switches using a non-crossover twisted pair cable.
- Full-duplex IEEE802.3x flow control, half-duplex backpressure flow control
- Console management port provided
- Port working status and statistics available
- Restart and reset to factory setting can be done both locally and remotely
- TFTP /FTP firmware upgrade available
- Can be installed into standard 19-inch chassis

## 1.2 Technical specifications

### ■ Protocols and Standards

- IEEE802.3 10BASE-T Ethernet
- IEEE802.3u 100BASE-TX/FX Fast Ethernet
- IEEE802.3x Flow control
- IEEE802.1x access control
- IEEE802.1D/w Spanning Tree
- IEEE802.1p Class of Service
- IEEE802.1Q VLAN
- IEEE802.3ad Link Aggregation
- TFTP/FTP
- DHCP
- BootP
- Telnet
- IP/UDP/TCP/ICMP
- HTTP
- SNMP V1/V2C
- RIP
- OSPF
- BGP

### ■ Management Protocols and Methods

- 
- CLI command line
  - SNMP V1/V2C enabled, available through Network management systems such as ECview
  - Telnet management enabled
  - RFC1757 RMON (1, 2, 3, 9)
  - **MIB Library**
  - RFC1213 MIB II
  - RFC1493 Bridge MIB
  - RFC1643 Ether-Like MIB
  - Edge-Core Private MIB

## 1.3 Physical Specifications

### ■ Management Port

- One RJ-45 serial port for each management module

### ■ AC Power Input

- 90 ~ 264VAC, 50 ~ 60Hz
- Built-in Universal Power Supply

### ■ Power Consumption

- ES4704BD: 400W Max
- ES4710BD: 1200W Max

### ■ Operating Temperature

- 0°C ~ 40°C

### ■ Storage Temperature

- 40°C ~ 70°C

### ■ Relative humidity

- 10% ~ 90% with no condensate

### ■ Dimension

- ES4704BD: 440mm x 266mm x 421mm (W x H x D)
- ES4710BD: 436mm x 797mm x 478mm (W x H x D)

### ■ Weight

- ES4704BD: 30kg (max. full configuration weight)
- ES4710BD: 65kg (max. full configuration weight)

### ■ Mean Time Before Failure

- Min. 80,000 Hours MTBF

## 1.4 Hardware Components

ES4704BD consists of the chassis, power supply system, ventilation system, system board, etc.

### 1.4.1 Chassis



---

### 1.4.1.1 ES4704BD Chassis

The ES4704BD uses a 19-inch Rack Mountable Chassis, with the standard dimensions of 440mm(W) x 266(H) x 421mm(D). The chassis consists of functional block and power supply block. The function module block is a board rack, which is the supporting structure for ES4704BD system boards (4 boards max). The fan block is located on the left side of the board rack, allowing one fan tray (4 axial fans for each fan tray). Dust gauze is provided on the right of the board rack for filtering air circulation through the rack. The power block upper the dust gauze provides power to the system, supporting up to two power modules. The power modules insert into the power slots from the front, with the distribution box at the back of the rack for maintenance. In addition, there is a ESD Wrist Strap Connectors on the board rack, located on the left side of the upper.

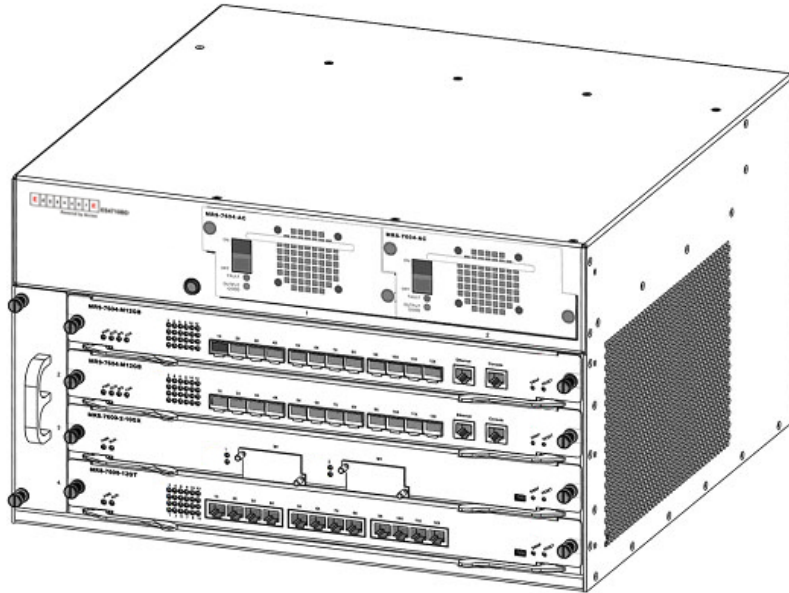

Fig 1-3 ES4704BD Module Outlook

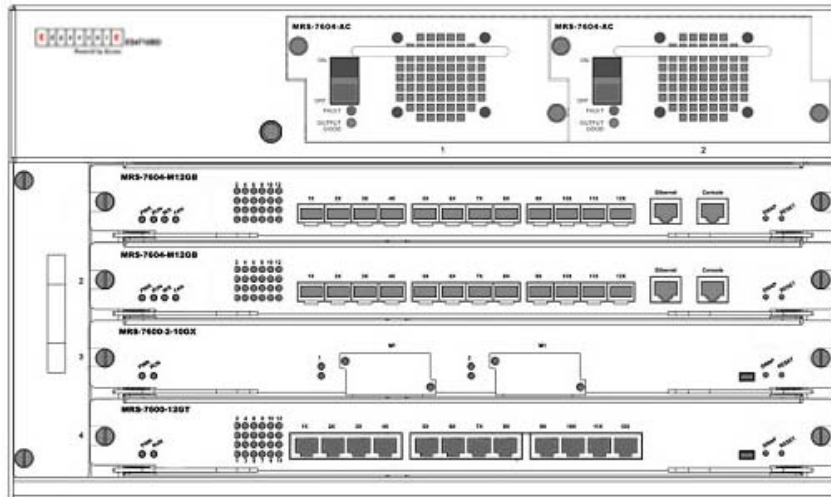

Fig 1-4 ES4704BD Front Panel View

- ① Management slot: It supports two management slots.  
EM4704BD-M24TX4GC or EM4704BD-M12GX-SFP can be inserted in to the Management slots. The second slot can also be used as I/O slot for configuring various I/O modules, such as EM4700BD-12GX-SFP , EM4700BD-12GT-RJ45 , EM4700BD-2XG-XENPAK and more.
- ② Network slot: 2 network slots are provided. Various network modules can be added to the network slots, such as EM4700BD-12GT-RJ45, EM4700BD-12GX-SFP, EM4700BD-2XG-XENPAK, etc.
- ③ Power slot: used for system power supply modules. Supports up to two 300W AC modules.
- ④ Fan tray slot: supports up to one system fan assemblies, each assembly consists of four axial fans.
- ⑤ Dust gauze slot: exterior air inlet for the ventilation subsystem.
- ⑥ Distribution box slot: for system distribution box use, works in AC mode based on the power modules.

### 1.4.1.1.1 Board Rack

The board rack consists of board slots and a system board.

The boards are inserted vertically into the ES4704BD 4 unit boards are provided. There are four slots in ES4704BD from number 1 to number 4 in order of top to down. The first slot is used to install management module; the second slot is used to management module under 1+1 redundant backup mode or install various I/O interface modules.

A reset button (printed on the panel as **Reset**), hot swap button (printed on the panel as **SWAP**), board power indicator (printed on the panel as **PWR**) and board running status indicator (printed on the panel as **RUN**) are provided for each board. On the Main Control cards there is Master-Slave indicator (printed on the panel as **M/S**) There is also a power module status indicator (printed on the panel as **Power**), fan assembly status indicator (printed on the panel as **Fan**), and interface status indicators for corresponding management interfaces and network interfaces (printed on the panel as **Link** and **Act**).

---

The ES4704BD system board is an essential part of the switch, located inside the switch and providing interconnectivity between the management switch modules (short for *management card*) and network interface modules (*line card*), and for all management and control signals.

#### **1.4.1.1.2 Power Supply**

When using A.C. power supply, we shall adopt power supply of 90~264v and corresponding A.C. distribution box. The permissible range of power supply is  $\pm 20\%$ , 50Hz~60Hz. The maximum output power of single power supply module is 300W.

#### **1.4.1.1.3 Ventilation and Cooling System**

The operating ambient temperature of the ES4704BD is 0 ~ 40°C, the thermal design of the equipment can ensure that the surface temperature of the device will not exceed the 50°C to 80°C, the highest temperature allowable.

The switch uses fan assemblies to disperse heat, with the air flow being drawn in through the right section and out through the left section to facilitate air circulation, so that the switch can maintain normal operation under specified environmental conditions. The fan tray is attached to the fan tray slots left the board rack, and ventilation is provided via 4 axial fans that pump out air. Fan trays are hot swappable for maintenance, their status are indicated by the FAN indicators on the main switch panel. In addition, dust gauze is provided on the right of the board rack for filtering the air circulating through the rack. The dust gauze can be unplugged and removed through the back for maintenance.

#### **1.4.1.2 ES4710BD Chassis**

The ES4710BD uses a 19-inch Rack Mountable Chassis, with the standard dimensions of 436mm(W) x 797(H) x 478mm(D). The chassis consists of functional block, thermal block, and power supply block. The function module block is a board rack, which is the supporting structure for ES4710BD system boards (10 boards max). Ten wiring clips are provided in the upper and lower parts of the board rack respectively, for the positioning of all kinds of cables. In addition, there are two ESD Wrist Strap Connectors on the board rack, located on the left side of the upper and lower rack respectively. The thermal block is located on the upper part of the board rack, allowing three fan trays (2 axial fans for each fan tray). Dust gauze is provided under the board rack for filtering air circulation through the rack. The power block under the dust gauze provides power to the system, supporting up to three power modules. The power modules insert into the power slots from the front, with the distribution box at the back of the rack for maintenance. Closely beside the distribution box, a grounding post has been provided on each side of the rack for grounding connections. In addition, on both sides of the lower section of the chassis, a handler is provided for easier transport.



Fig 1-5 ES4710BD Front Panel view

- 
- ① Management slot: 2 management slots are provided. One or two management switching modules EM4710BD-AGENT can be inserted in to the Management slots.
  - ② Network slot: 8 network slots are provided. Various network modules can be added to the network slots, such as EM4700BD-12GT-RJ45, EM4700BD-12GX-SFP, EM4700BD-2XG-XENPAK, etc.
  - ③ Power slot: used for system power supply modules. Supports up to three 600W AC modules.
  - ④ Fan tray slot: supports up to three system fan assemblies, each assembly consists of two axial fans.
  - ⑤ Dust gauze slot: exterior air inlet for the ventilation subsystem.
  - ⑥ Distribution box slot: for system distribution box use, works in AC mode based on the power modules.
- 

### 1.4.1.2.1 Board Rack

The board rack consists of board slots and a system board.

The boards are inserted vertically into the ES4710BD 10 unit boards are provided. These include 2 management slots in the middle for management switch modules, marked specially in red as M1 and M2. The other eight board slots are network slots for various network interface modules, sequenced as 1 to 8 from left to right.

A reset button (printed on the panel as **Reset**), hot swap button (printed on the panel as **SWAP**), board power indicator (printed on the panel as **PWR**) and board running status indicator (printed on the panel as **RUN**) are provided for most board. On the Main Control cards there is Master-Slave indicator (printed on the panel as **M/S**) There is also a power module status indicator (printed on the panel as **Power: Fail/OK**), fan assembly status indicator (printed on the panel as **Fan: Alarm/OK**), and interface status indicators for

---

corresponding management interfaces and network interfaces (printed on the panel as **Link** and **Act**).

The ES4710BD system board is an essential part of the switch, located inside the switch and providing interconnectivity between the management switch modules (short for management card) and network interface modules (line card), and for all management and control signals.

### 1.4.1.2.2 Power Supply

When powered by AC sources, the 110V/220 VAC input power supplies and corresponding AC distribution box should be used. The acceptable input power ranges from 90 ~ 264 VAC at 50 ~ 60 Hz. The maximum output power of each power module is 600W.

### 1.4.1.2.3 Ventilation and Cooling System

The operating ambient temperature of the ES4710BD is 0 ~ 40°C, the thermal design of the equipment can ensure that the surface temperature of the device will not exceed the 50°C to 80°C, the highest temperature allowable.

The switch uses fan assemblies to disperse heat, with the air flow being drawn in through the bottom section and out through the upper section to facilitate air circulation, so that the switch can maintain normal operation under specified environmental conditions. Three fan trays are attached to the fan tray slots above the board rack, and ventilation is provided via 6 axial fans that pump out air. Fan trays are hot swappable for maintenance, their status are indicated by the FAN indicators on the main switch panel. In addition, dust gauze is provided under the board rack for filtering the air circulating through the rack. The dust gauze can be unplugged and removed through the front for maintenance.

## 1.4.2 Introduction to ES4700BD cards

The following twelve cards for the ES4700BD are currently available:

- Main control card (EM4704BD-M12GX-SFP): The central switching and controlling module for the ES4704BD, System status control, switch management, user access control and administration, and network operation maintenance are performed here. 12 Gigabit SFP ports are also provided.
- Main control card (EM4704BD-M24TX4GC): The central switching and controlling module for the ES4704BD, System status control, switch management, user access control and administration, and network operation maintenance are performed here. 24 10/10Base-TX ports with 4 Gigabit combo ports(RJ45or SFP) are also provided.
- Main control card (EM4710BD-AGENT): The central switching and controlling module for the ES4710BD. System status control, switch management, user

---

access control and administration, and network operation maintenance are performed here.

- 12 copper GT ports line card (EM4700BD-12GT-RJ45): supporting 12 1000Base-T copper ports for layer 2 and layer 3 switching and routing.
- 12 fiber GB ports line card (EM4700BD-12GX-SFP): supporting 12 fiber GB fiber ports for layer 2 and layer 3 switching and routing.
- Dual 10GB fiber line card (EM4700BD-2XG-XENPAK): supporting 2 10GBase-X fiber ports (XENPAK) for layer 2 and layer 3 switching and routing.
- 8 Gigabit Combo ports and 16 fiber GB ports line card(EM4700BD-8GC16GX): supporting 8 Gigabit Combo and 16 fiber GB ports for layer 2 and layer 3 switching and routing; ipv6 wire speed forward
- Dual 10G XFP ports , 8 Gigabit Combo ports and 16 fiber GB ports line card (EM4700BD-8GC16GX2XG): supporting 2 10G XFP ports, 8 Gigabit Combo and 16 fiber GB port for layer 2 , layer 3 switching and routing and ipv6 wire speed forward
- 4 Gigabit Combo ports and 24 100/10 Base-TX ports line card (EM4700BD-24TX4GC): supporting 4 Gigabit Combo ports and 24 100/10 Base-TX ports for layer 2 and layer 3 switching and routing.
- 12 Gigabit Combo ports and 12 copper GT ports(EM4700BD-12GT12GC): supporting 12 Gigabit Combo ports and 12 copper GT ports for layer 2 and layer 3 switching and routing and ipv6 wire speed forward
- Dual 10G XFP ports , 12 Gigabit Combo ports and 12 copper Gb ports (EM4700BD-12GT12GC2XG): supporting dual 10G XFP ports, 12 Gigabit Combo ports and 12 copper GT ports for layer 2 and layer 3 switching , routing and ipv6 wire speed forward
- 48 copper GT ports line card (EM4700BD-48GT): supporting 48 1000Base-T copper ports for layer 2 and layer 3 switching and routing and ipv6 wire speed forward.
- 48-port 1000Mbps optical line card (EM4700BD-48GX-SFP) : implements 2-layer and 3-layer wire-speed switching and routing function of 48 1000Mbps optical interfaces, and IPv6 wire-speed transmission.
- Four 10G XFP ports line card (EM4700BD-4XG-XFP): implements 2-layer and 3-layer wire-speed switching and routing function of 4 10,000 Mbps XFP interfaces and IPv6 wire-speed transmission. This network-control chip RTL8139 does not support MDIX function.

### **1.4.2.1 EM4704BD-M12GX-SFP**

The EM4704BD-M12GX-SFP is switching module for the ES4704BD. System status control, switch management, user access control and administration, and network maintenances are performed here. The board can be inserted into first or second slots of the chassis for Master-Slave redundancy. 12 Gigabit SFP ports are also provided.

### 1.4.2.1.1 Front Panel

The EM4704BD-M12GX-SFP provides 12 1000Base-SFP ports. At the same time, it comes with 1 Console port (control console) and 1 10/100Base-Tx Ethernet port (management port).

The Front Panel view is shown below:

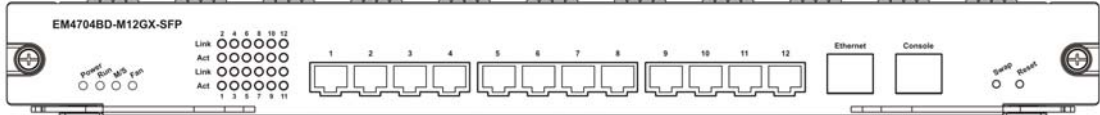

Fig 1-6 EM4704BD-M12GX-SFP Front Panel View

### 1.4.2.1.2 Front Panel - Indicator

The following table describes the front panel indicators of EM4704BD-M12GX-SFP:

Table 1.1EM4704BD-M12GX-SFP indicators description

LED	Panel Symbol	Status	Description
Power Indicator	PWR	On (Green)	Card powered
		Off	Card powered off
Operation indicator	RUN	On (Green, blink at 1 Hz)	Cards operating normally
		On (Green, blink at 8 Hz)	System is loading
		On (Yellow, blink at 8 Hz)	System is shutting down
		On (Red, blink at 8 Hz)	Cards malfunction
		Off	Cards are powered off and can be removed
Master-Slave indicator	M/S	On (Green)	Master
		Off	Slave
Fan Assembly Status indicator: FAN	OK	On (Green)	Fan operating normally
		Off	Fan malfunctioning or not present (with <b>Alarm</b> off)
SFP port indicator			
Status indicator	Link	On (Green)	Network connection on SFP transceiver is normal

		Off	No network connection present on SFP transceiver
Transmission Indicator	Act	Blinking (Green)	Sending or receiving data

### 1.4.2.1.3 Front Panel Port Description

The EM4704BD-M12GX-SFP provides 12 SFP (Mini GBIC) Gigabyte fiber transceiver slots.

The following SFP transceivers are supported by the EM4704BD-M12GX-SFP:

- ET4201-SX            Gigabit SFP MM 850 nm, 500m (SX)
- ET4201-LX           Gigabit SFP SM 1310 nm, 10Km (LX)
- ET4201-LHX         Gigabit SFP SM 1310 nm, 40Km (LHX)
- ET4201-ZX           Gigabit SFP SM 1550 nm, 80Km (ZX)
- ET4201-RJ45        Gigabit SFP to Copper cable RJ45

### 1.4.2.1.4 Front Panel – Console Port

The EM4704BD-M12GX-SFP provides a RJ-45 (receptacle) Console serial port. Users can connect to hosts via this port to perform system debugging, configuration, maintenance, management and host software loading.

Table 1.2 EM4704BD-M12GX-SFP Console description

Property	Specification
Connector	RJ-45 (receptacle)
Connector type	RS-232
Baud rate	9600bps (default)
Supporting service	<ul style="list-style-type: none"> <li>• Connects to character terminals</li> <li>• Connects to PC serial port and running terminal emulator on PC.</li> </ul>

### 1.4.2.1.5 Front Panel – Management Port

The EM4704BD-M12GX-SFP provides a RJ-45 (receptacle) Ethernet port. Users can connect through this management port to hosts for program loading or to connect to remote devices for remote management (e.g., a managing workstation). Note: when connecting to the host, a cross-over cable should be used.

Table 1.3 EM4704BD-M12GX-SFP management port description

Property	Specification
----------	---------------



Connector	RJ-45 (Receptacle)
Connector type	<ul style="list-style-type: none"> <li>• 10/100Mbps auto sensing</li> <li>• Cat 5 UTP: 100 m</li> </ul>

### 1.4.2.1.6 Front Panel – Reset Button

EM4704BD-M12GX-SFP provides a RESET button for resetting the board.

### 1.4.2.2 EM4704BD-M24TX4GC

The EM4704BD-M24TX4GC is switching module for the ES4704BD. System status control, switch management, user access control and management, and network maintenances are performed here. The board can be inserted into first or second slots of the chassis for Master-Slave redundancy. 24 10/10Base-TX ports with 4 Gigabit combo ports(RJ45or SFP) are also provided.

#### 1.4.2.2.1 Front Panel

The EM4704BD-M24TX4GC provides 24 10/100Base-TX ports and 4 Gigabit COMBO slots. At the same time, it comes with 1 Console port (control console) and 1 10/100Base-Tx Ethernet port (administration port).

The Front Panel view is shown below:

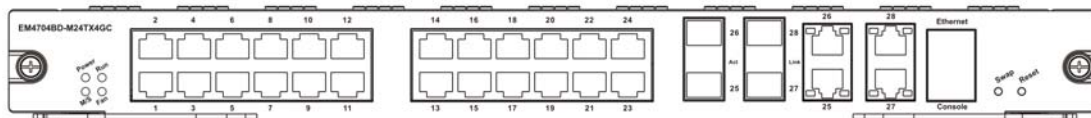

Fig 1-7 EM4704BD-M24TX4GC

#### 1.4.2.2.2 Front Panel - Indicator

The following table describes the front panel indicators of EM4704BD-M24TX4GC:

Table 1.4 EM4704BD-M24TX4GC indicators description

LED	Panel Symbol	Status	Description
Power Indicator	PWR	On (Green)	Card powered
		Off	Card powered off
Operation indicator	RUN	On (Green, blink at 1 Hz)	Cards operating normally
		On (Green, blink at 8 Hz)	System is loading

		On (Yellow, blink at 8 Hz)	System is shutting down
		On (Red, blink at 8 Hz)	Cards malfunction
		Off	Cards are powered off and can be removed
Master-Slave indicator	M/S	On (Green)	Master
		Off	Slave
Fan Assembly Status indicator: FAN	FAN	On (Green)	Fan operating normally
		On (Red)	Fan malfunctioning
		Off	Fan not present (with <b>Alarm</b> off)
SFP port indicator			
Status indicator	Link	On (Green)	Network connection on SFP transceiver is normal
		Off	No network connection present on SFP transceiver
Transmission Indicator	Act	Blinking (Green)	Sending or receiving data
10/100Base-RJ45 port indicator			
Status indicator	Link	On (Green)	Network connection is normal
		Off	No network connection present on 10/100Base-RJ45 port
Transmission Indicator	Act	Blinking (Green)	Sending or receiving data
1000Base-TX port indicator			
Status indicator	Link	On (Green)	Network connection on 1000Base-TX transceiver is normal
		Off	No network connection present on 1000Base-TX transceiver
Transmission Indicator	Act	Blinking (Green)	Sending or receiving data

### 1.4.2.2.3 Front Panel Port Description

The EM4704BD-M24TX4GC provides 24 10/100Base-TX ports and 4 Gigabit COMBO (RJ-45 or SFP ) transceiver slots.

The following SFP transceivers are supported by the EM4704BD-M24TX4GC:

- ET4201-SX                      Gigabit SFP MM 850 nm, 500m (SX)

- ET4201-LX Gigabit SFP SM 1310 nm, 10Km (LX)
- ET4201-LHX Gigabit SFP SM 1310 nm, 40Km (LHX)
- ET4201-ZX Gigabit SFP SM 1550 nm, 80Km (ZX)
- ET4201-RJ45 Gigabit SFP to Copper cable RJ45

#### 1.4.2.2.4 Front Panel – Console Port

The EM4704BD-M24TX4GC provides a RJ-45 (receptacle) Console serial port. Users can connect to hosts via this port to perform system debugging, configuration, maintenance, management and host software loading.

Table 1.5 EM4704BD-M24TX4GC Console description

Property	Specification
Connector	RJ-45 (receptacle)
Connector type	RS-232
Baud rate	9600bps (default)
Supporting service	<ul style="list-style-type: none"> <li>• Connects to character terminals</li> <li>• Connects to PC serial port and running terminal emulator on PC.</li> </ul>

#### 1.4.2.2.5 Front Panel – Management Port

The EM4704BD-M24TX4GC provides a RJ-45 (receptacle) Ethernet port. Users can connect through this management port to hosts for program loading or to connect to remote devices for remote management (e.g., a managing workstation). Note: when connecting to the host, a cross-over cable should be used.

Table 1.6 EM4704BD-M24TX4GC management port description

Property	Specification
Connector	RJ-45 (Receptacle)
Connector type	<ul style="list-style-type: none"> <li>• 10/100Mbps auto sensing</li> <li>• Cat 5 UTP: 100 m</li> </ul>

#### 1.4.2.2.6 Front Panel – Reset Button

EM4704BD-M24TX4GC provides a RESET button for resetting the board.

#### 1.4.2.3 EM4710BD-AGENT

The EM4710BD-AGENT is switching module for the ES4710BD. System status control, switch management, user access control and management, and network maintenances are performed here. The board can be inserted into M1 or M2 slots of the chassis for Master-Slave redundancy.

### 1.4.2.3.1 Front Panel

The EM4710BD-AGENT comes with 1 Console port (control console) and 1 10/100Base-Tx Ethernet port (management port).

The Front Panel view is shown below:



Fig 1-8 EM4710BD-AGENT Front Panel view

### 1.4.2.3.2 Front Panel - Indicator

The following table describes the front panel indicators of EM4710BD-AGENT:

Table 1.7 EM4710BD-AGENT indicators description

LED	Panel Symbol	Status	Description
Power Indicator	PWR	On (Green)	Card powered
		Off	Card powered off
Operation indicator	RUN	On (Green, blink at 1 Hz)	Cards operating normally
		On (Green, blink at 8 Hz)	System is loading
		On (Yellow, blink at 8 Hz)	System is shutting down
		On (Red, blink at 8 Hz)	Cards malfunction
		Off	Cards are powered off and can be removed
Master-Slave indicator	M/S	On (Green)	Master
		Off	Slave
Power Supply Module Status indicator: <i>POWER</i>	OK	On (Green)	Power Supply Module operating normally
		Off	Power supply module malfunctioning or not present (with <b>Fail</b> off)
	<i>Fail</i>	On (Yellow)	Power Supply Module malfunction

		Off	Power supply module operating normally or not present (with <b>OK</b> off)
Fan Assembly Status indicator: FAN	OK	On (Green)	Fan operating normally
		Off	Fan malfunctioning or not present (with <b>Alarm</b> off)
	Alarm	On (Yellow)	Fan malfunction
		Off	Fan operating normally or not present (with <b>OK</b> off)

### 1.4.2.3.3 Front Panel – Console Port

The EM4710BD-AGENT provides a RJ-45 (receptacle) Console serial port. Users can connect to hosts via this port to perform system debugging, configuration, maintenance, management and host software loading.

Table 1.8 EM4710BD-AGENT Console description

Property	Specification
Connector	RJ-45 (receptacle)
Connector type	RS-232
Baud rate	9600bps (default)
Supporting service	<ul style="list-style-type: none"> <li>Connects to character terminals</li> <li>Connects to PC serial port and running terminal emulator on PC.</li> </ul>

### 1.4.2.3.4 Front Panel – Management Port

The EM4710BD-AGENT provides a RJ-45 (receptacle) Ethernet port. Users can connect through this management port to hosts for program loading or to connect to remote devices for remote management (e.g., a managing workstation). Note: when connecting to the host, a cross-over cable should be used.

Table 1.9 EM4710BD-AGENT management port description

Property	Specification
Connector	RJ-45 (Receptacle)
Connector type	<ul style="list-style-type: none"> <li>10/100Mbps auto sensing</li> <li>Cat 5 UTP: 100 m</li> </ul>

### 1.4.2.3.5 Front Panel – Reset Button

EM4710BD-AGENT provides a RESET button for resetting the board.

## 1.4.2.4 EM4700BD-12GT-RJ45

12 copper GT ports line card (EM4700BD-12GT-RJ45): supports 12 1000Base-T copper ports for layer 2 and layer 3 switching and routing.

### 1.4.2.4.1 Front Panel

The EM4700BD-12GT-RJ45 provides 12 RJ45 ports (10/100/1000Mbps adaptive). The Front Panel view is shown below:

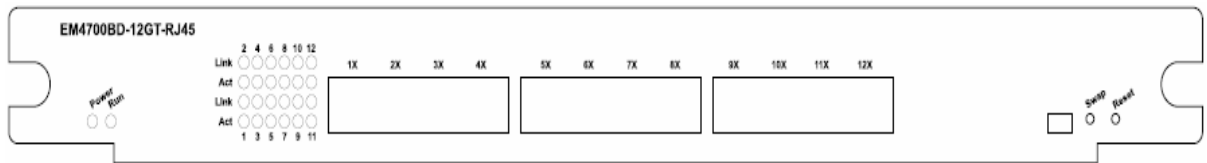

Fig 1-9 EM4700BD-12GT-RJ45 Front Panel view

### 1.4.2.4.2 Front Panel - Indicator

The following table describes the EM4700BD-12GT-RJ45's front panel indicators:

Table 1.10 EM4700BD-12GT-RJ45 indicator descriptions

LED	Panel Symbol	Status	Description
Power Indicator	PWR	On (green)	Card powered
		Off	Card powered off
Operation indicator	RUN	On (Green, blinks at 1 Hz)	Card operating normally
		On (Green, blinks at 8 Hz)	System is loading
		On (Yellow, blinks at 8 Hz)	System is shutting down
		On (Red, blinks at 8 Hz)	Malfunction status
		Off	Card is powered off and can be removed
RJ-45 port indicator			
Status indicator	Link	On (Green)	Network connection is normal
		Off	No network connection present on 1000Base-TX port

Transmission Indicator	Act	Blinking (Green)	Sending or receiving data
------------------------	-----	------------------	---------------------------

### 1.4.2.4.3 Front Panel Port Description

The EM4700BD-12GT-RJ45 provides 12 RJ45 copper GT ports.

Table 1.11 EM4700BD-12GT-RJ45 port description

Port Type	Specification
RJ-45 port	<ul style="list-style-type: none"> <li>• 10/100/1000 Mbps auto sensing</li> <li>• MDI/MDI-X cable ant sensing</li> <li>• Cat 5 UTP: 100 m</li> </ul>

### 1.4.2.4.4 Front Panel – Reset Button

The EM4700BD-12GT-RJ45 provides a **RESET** button for resetting the board.

### 1.4.2.5 EM4700BD-12GX-SFP

12 fiber GB ports line card (EM4700BD-12GX-SFP): supports 12 SFP GB fiber ports for layer 2 and layer 3 switching and routing.

#### 1.4.2.5.1 Front Panel

EM4700BD-12GX-SFP provides 12 SFP ports. The Front Panel view is shown below:

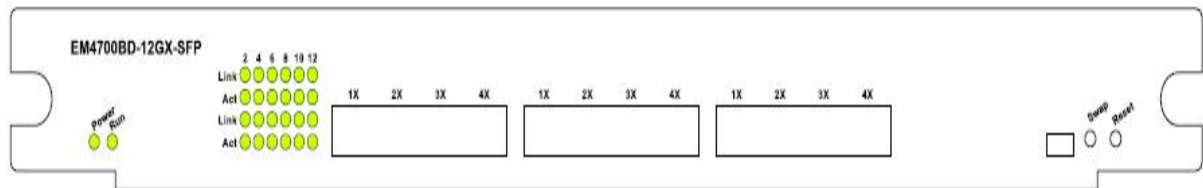

Fig 1-10 EM4700BD-12GX-SFP Front Panel view

#### 1.4.2.5.2 Front Panel - Indicator

The following table describes the EM4700BD-12GX-SFP's front panel indicators:

Table 1.12 EM4700BD-12GX-SFP indicator descriptions

LED	Panel Symbol	Status	Description
Power Indicator	PWR	On (green)	Card powered
		Off	Card powered off

Operation indicator	RUN	On (Green, blinks at 1 Hz)	Cards operating normally
		On (Green, blinks at 8 Hz)	System is loading
		On (Yellow, blinks at 8 Hz)	System is shutting down
		On (Red, blinks at 8 Hz)	Malfunction status
		Off	Cards is powered off and can be removed
SFP port indicator			
Status indicator	Link	On (Green)	Network connection on SFP transceiver is normal
		Off	No network connection present on SFP transceiver
Transmission Indicator	Act	Blinking (Green)	Sending or receiving data

### 1.4.2.5.3 Front Panel Port Description

The EM4700BD-12GX-SFP provides 12 SFP (Mini GBIC) Gigabyte fiber transceiver slots.

The following SFP transceivers are supported by the EM4700BD-12GX-SFP:

- ET4201-SX            Gigabit SFP MM 850 nm, 500m (SX)
- ET4201-LX           Gigabit SFP SM 1310 nm, 10Km (LX)
- ET4201-LHX         Gigabit SFP SM 1310 nm, 40Km (LHX)
- ET4201-ZX           Gigabit SFP SM 1550 nm, 80Km (ZX)
- ET4201-RJ45        Gigabit SFP to Copper cable RJ45

### 1.4.2.5.4 Front Panel – Reset Button

The EM4700BD-12GX-SFP provides a RESET button for resetting the board.

### 1.4.2.6 EM4700BD-2XG-XENPAK

Dual 10GbE fiber line card (EM4700BD-2XG-XENPAK): supporting 2 XENPAK 10Gb fiber port for layer 2 and layer 3 switching and routing.

#### 1.4.2.6.1 Front Panel

The EM4700BD-2XG-XENPAK provides 2 XENPAK 10Gb fiber transceiver ports, the front panel view is shown below:



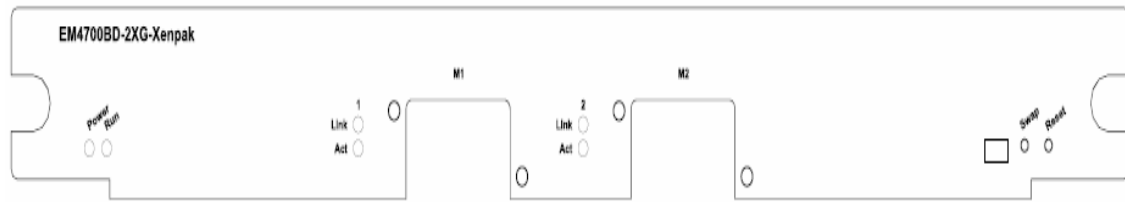

Fig 1-11 EM4700BD-2XG-XENPAK front panel view

### 1.4.2.6.2 Front Panel - Indicator

The following table describes the front panel indicators for the EM4700BD-2XG-XENPAK:

Table 1.13 Description of the EM4700BD-2XG-XENPAK indicators

LED Indicator	Panel Symbol	Status	Description
Power Indicator	PWR	On (green)	Card powered.
		Off	Card powered off
Operation indicator	RUN	On (Green, blinks at 1 Hz)	Card operating normally
		On (Green, blinks at 8 Hz)	System is loading
		On (Yellow, blinks at 8 Hz)	System is shutting down
		On (Red, blinks at 8 Hz)	Malfunction status
		Off	Card is powered off and can be removed.
XENPAK port indicator			
Status indicator:	Link	On (Green)	Network connection on XENPAK transceiver is normal
		Off	No network connection present on XENPAK transceiver
Transmission Indicator	Act	Blinking (Green)	Sending or receiving data

### 1.4.2.6.3 Front Panel Port Description

EM4700BD-2XG-XENPAK provides 2 XENPAK 10Gb fiber transceiver slots;

Table 1.14 XENPAK port descriptions

Port Type	Specification
XENPAK	<ul style="list-style-type: none"> <li>XENPAK-SC transceiver (10GBASE-LR LAN-PHY) (Agilent HFCT-701XB, LAN mode, wavelength 1310nm): 62.5/125 µm multi-mode fiber (MMF): 300m 9/125 µm single-mode fiber (SMF): 10Km</li> </ul>

### 1.4.2.6.4 Front Panel – Reset Button

The EM4700BD-2XG-XENPAK provides a **RESET** button for resetting the board.

### 1.4.2.7 EM4700BD-8GC16GX and EM4700BD-8GC16GX2XG

EM4700BD-8GC16GX line card :supporting 8 gigabit combo ports and 16 fiber GB ports for layer2 and layer3 switching and routing and IPv6 wire speed forward.

EM4700BD-8GC16GX2XG line card: supporting dual 10G XFP ports, 8 gigabit combo ports and 16 fiber GB ports for layer2 and layer3 switching and routing and IPv6 wire speed forward.

#### 1.4.2.7.1 Front Panel Diagram

EM4700BD-8GC16GX provides eight GT electronic ports, twenty four GB optical SFP ports, where the eight 1G electronic ports and the first eight 1G optical ports are combo ports.

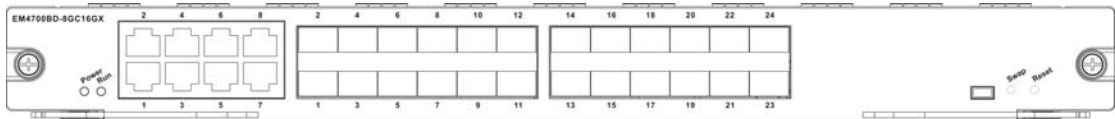

Fig 1-12 EM4700BD-8GC16GX front panel view

EM4700BD-8GC16GX2XG provides two 10G XFP ports, eight 1G electronic ports, twenty four 1G optical SFP ports, where the eight 1G electronic ports and the first eight 1G optical ports are combo ports.

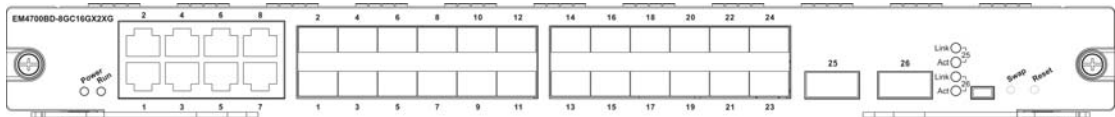

Fig 1-13 EM4700BD-8GC16GX2XG front panel view

#### 1.4.2.7.2 Front Panel Indicator

The description of front panel indicator of EM4700BD-8GC16GX and EM4700BD-8GC16GX2XG is as follows:

Table 1.15 EM4700BD-8GC16GX and EM4700BD-8GC16GX2XG indicator description

LED Indicator	Panel Sign	Status	Meanings
Power Indicator	PWR	On (Green)	Network Interface Card power on
		Off	Network Interface Card power off

Running Indicator	RUN	On (Green 1Hz flash)	Network Interface Card running in normal status
		On (Green 8Hz flash)	System loading (Network Interface Card Booting after hot plug in)
		On (Yellow 8Hz flash)	System shutting down
		On (Red 8Hz flash)	Running status is in failure
		Off	Network Interface Card is off and can be pulled out
RJ-45 Interface indicator			
Status Indicator	“Left Light”	On (Green)	RJ-45 Interface Network Connection is normal
		Off	There is not network connection at RJ-45 interface
Transmission Indicator	“Right Light”	Flashed (Green)	Sending or receiving data
SFP Interface Indicator			
Status Indicator	“Left Light”	On (Green)	SFP transceiver network connection is normal
		Off	There is not network connection at SFP transceiver
Transmission Indicator	“Right Light”	Flashes (Green)	Sending or receiving data
XFP Interface Indicator			
Status Indicator	Link	On (Green)	XFP transceiver network connection is normal
		Off	There is not network connection at XFP transceiver
Transmission Indicator	Act	On (Green)	Sending or receiving data

### 1.4.2.7.3 Front Panel Interface Description

EM4700BD-8GC16GX and EM4700BD-8GC16GX2XG provide eight RJ-45 1G electronic ports, twenty four SFP 1G optical fibre transceiver slots.

EM4700BD-8GC16GX2XG provides two XFP 10G electronic ports.

EM4700BD-8GC16GX and EM4700BD-8GC16GX2XG support the followings SFP transceiver:

- ET4201-SX                      Gigabit SFP MM 850 nm, 500m (SX)
- ET4201-LX                      Gigabit SFP SM 1310 nm, 10Km (LX)

- ET4201-LHX            Gigabit SFP SM 1310 nm, 40Km (LHX)
- ET4201-ZX            Gigabit SFP SM 1550 nm, 80Km (ZX)
- ET4201-RJ45        Gigabit SFP to Copper cable RJ45

EM4700BD-8GC16GX2XG supports XFP transceivers of the following types:

- ET5302-LR            XFP 10G Transceiver 10KM
- ET5302-ER            XFP 10G Transceiver 40km
- ET5302-SR            XFP 10G Transceiver 300M

#### 1.4.2.7.4 Front Panel RESET Button

EM4700BD-8GC16GX and EM4700BD-8GC16GX2XG both provide a RESET button to reset the panel.

#### 1.4.2.8 EM4700BD-24TX4GC

EM4700BD-24TX4GC is the line card model of ES4700BD series switches. It implements the layer2 and layer3 wire speed forward and routing function of twenty four 10/100M electronic ports and four 1G COMBO (4 10/100/1000M electronic interfaces or four 1G optical interfaces).

##### 1.4.2.8.1 Front Panel Diagram

EM4700BD-24TX4GC provides twenty four 10/100M electronic ports and four 1G COMBO.

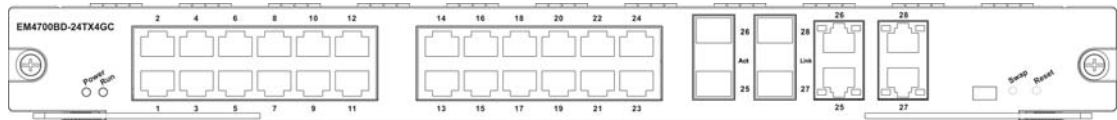

Fig 1-14 EM4700BD-24TX4GC front panel view

##### 1.4.2.8.2 Front Panel Indicator

The description of front panel indicator of EM4700BD-24TX4GC is as follows:

Table 1.16 EM4700BD-24TX4GC indicator description

Indicator	Panel Sign	Status	Meanings
Power Indicator	PWR	On (Green)	Network Interface Card power on

		Off	Network Interface Card power off
Running Indicator	RUN	On (Green 1Hz flash)	Network Interface Card running in normal status
		On (Green 8Hz flash)	System loading (Network Interface Card Booting after hot plug in)
		On (Yellow 8Hz flash)	System shutting down
		On (Red 8Hz flash)	Running status is in failure
		Off	Network Interface Card is off and can be pulled out
SFP Interface indicator			
Status Indicator	Link	On (Green)	SFP transceiver network connection is normal
		Off	There is not network connection at SFP transceiver
Transmission Indicator	Act	Flashes (Green)	Sending or receiving data
100MB electronic port indicator			
Status Indicator	Link	On (Green)	100MB electronic port transceiver network connection is normal
		Off	There is not network connection at 100MB electronic port transceiver
Transmission Indicator	Act	Flashes (Green)	Sending or receiving data
1GB Electronic Port Indicator			
Status Indicator	Link	Flashes (Green)	1GB electronic port transceiver network connection is normal
		Off	There is not network connection at 1GB electronic port transceiver
Transmission Indicator	Act	Flashes (Green)	Sending or receiving data

---

### 1.4.2.8.3 Front Panel Interface Description

EM4700BD-24TX4GC provides twenty four 10/100M and four 1G COMBO.

Where 1G optical electronic port, EM4700BD-24TX4GC supports SFP transceivers of the following types:

- ET4201-SX            Gigabit SFP MM 850 nm, 500m (SX)
- ET4201-LX            Gigabit SFP SM 1310 nm, 10Km (LX)
- ET4201-LHX           Gigabit SFP SM 1310 nm, 40Km (LHX)
- ET4201-ZX            Gigabit SFP SM 1550 nm, 80Km (ZX)
- ET4201-RJ45           Gigabit SFP to Copper cable RJ45

### 1.4.2.8.4 Front Panel RESET Button

EM4700BD-24TX4GC provides a RESET button to reset the panel.

### 1.4.2.9 EM4700BD-12GT12GC and EM4700BD-12GT12GC2XG

12-port optical-electronic combo and 12-port electronic interface line card (EM4700BD-12GT12GC): to implement the layer2 and layer3 wire speed exchange and routing function of 12-port 1G optical-electronic combo and 12-port 1G electronic interface and IPv6 wire speed transmission function.

Double 10G and 12-port optical-electronic combo and 12-port electronic interface line card (EM4700BD-12GT12GC2XG): to implement the layer2 and layer3 wire speed exchange and routing function of 12-port 1G optical-electronic combo, 12-port 1G electronic and 2-port 10G XFP interface, and IPv6 wire speed transmission function.

#### 1.4.2.9.1 Front Panel Diagram

EM4700BD-12GT12GC provides twelve 1G SFP ports, twenty four 1G electronic ports, where the twelve 1G optical ports and the last twelve 1G electronic ports are combo ports.

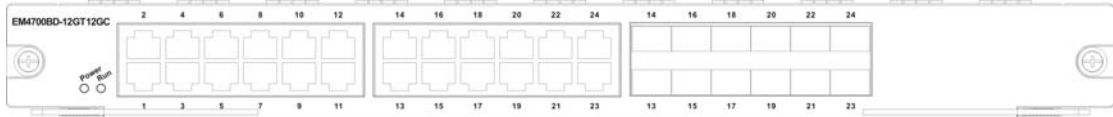

Fig 1-15 EM4700BD-12GT12GC front panel view

EM4700BD-12GT12GC2XG provides two 10G XFP ports, twelve 1G optical SFP ports, twenty four 1G electronic SFP ports, where the twelve 1G optical ports and the last twelve 1G electronic ports are combo ports.

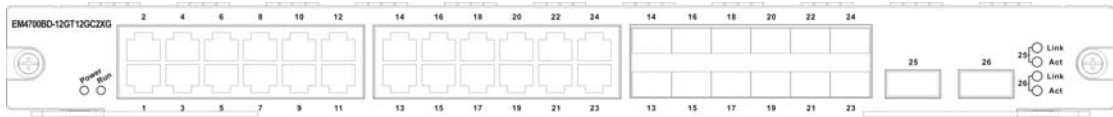

Fig 1-16 EM4700BD-12GT12GC2XG front panel view

### 1.4.2.9.2 Front Panel Indicator

The description of front panel indicator of EM4700BD-12GT12GC and EM4700BD-12GT12GC2XG is as follows:

Table 1.17 EM4700BD-12GT12GC and EM4700BD-12GT12GC2XG indicator description

LED Indicator	Panel Sign	Status	Meanings
Power Indicator	PWR	On (Green)	Network Interface Card power on
		Off	Network Interface Card power off
Running Indicator	RUN	On (Green 1Hz flash)	Network Interface Card running in normal status
		On (Green 8Hz flash)	System loading (Network Interface Card Booting after hot plug in)
		On (Yellow 8Hz flash)	System shutting down
		On (Red 8Hz flash)	Running status is in failure
		Off	Network Interface Card is off and can be pulled out
RJ-45 Interface indicator			
Status Indicator	Shared	On (Green)	RJ-45 Interface Network Connection is normal
		Off	There is not network connection at RJ-45 interface
Transmission Indicator		On (Yellow)	Sending or receiving data
SFP Interface Indicator			
Status Indicator	"Left Light"	On (Green)	SFP transceiver network connection is normal
		Off	There is not network connection at SFP interface
Transmission Indicator	"Right Light"	Flashes (Green)	Sending or receiving data
XFP interface Indicator			
Status Indicator	Link	On (Green)	XFP transceiver network connection is normal
		Off	There is not network connection at XFP transceiver
Transmission	Act	Flashes (Green)	Sending or receiving data

n Indicator			
-------------	--	--	--

### 1.4.2.9.3 Front Panel Interface Description

EM4700BD-12GT12GC and EM4700BD-12GT12GC2XG provide twelve SFP 1G optical fibre transceivers and twenty four RJ-45 1G electronic port slots.

EM4700BD-12GT12GC2XG provides two XFP 10G optical ports.

EM4700BD-12GT12GC and EM4700BD-12GT12GC2XG support SFP transceivers of the following types:

- ET4201-SX            Gigabit SFP MM 850 nm, 500m (SX)
- ET4201-LX           Gigabit SFP SM 1310 nm, 10Km (LX)
- ET4201-LHX         Gigabit SFP SM 1310 nm, 40Km (LHX)
- ET4201-ZX           Gigabit SFP SM 1550 nm, 80Km (ZX)
- ET4201-RJ45        Gigabit SFP to Copper cable RJ45

EM4700BD-12GT12GC2XG supports XFP transceivers of the following types:

- ET5302-LR           XFP 10G Transceiver 10KM
- ET5302-ER           XFP 10G Transceiver 40km
- ET5302-SR           XFP 10G Transceiver 300M

### 1.4.2.10 EM4700BD-48GT

48GT electronic interface line card (EM4700BD-48GT): to implement the layer2 and layer3 wire speed exchange and routing function of 48GT electronic interface and IPv6 wire speed transmission function.

#### 1.4.2.10.1 Front Panel Diagram

EM4700BD-48GT provides 48-Port 10/100/1000M Ethernet electronic ports,

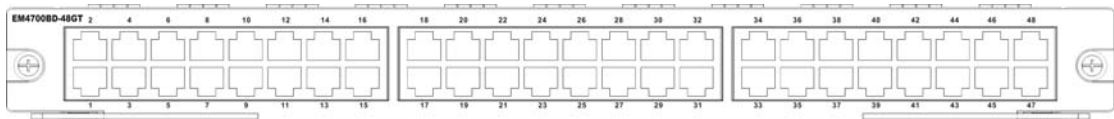

Fig 1-17 EM4700BD-48GT front panel view

#### 1.4.2.10.2 Front Panel Indicator

The description of front panel indicator of EM4700BD-48GT as follows:

Table 1.18 EM4700BD-48GT indicator description

LED Indicator	Panel Sign	Status	Meanings
---------------	------------	--------	----------



RJ-45 Interface indicator			
Status Indicator	Shared	On (Green)	RJ-45 Interface Network Connection is normal
		Off	There is not network connection at RJ-45 interface
Transmission Indicator		On (Yellow)	Sending or receiving data

### 1.4.2.10.3 Front Panel Interface Description

EM4700BD-48GT provide 48-port 10/100/1000M RJ-45 electronic port.

All kinds of interface description are as follows

Table 1.19 EM4700BD-48GT interface description

Interface Format	Specs
RJ-45 port	<ul style="list-style-type: none"> <li>• 10/100/1000Mbps self-adapting</li> <li>• MDI/MDI-X network wire type self-adapting</li> <li>• 5 kinds of Unshielded Twisted Pair(UTP): 100 metres</li> </ul>

### 1.4.2.11 EM4700BD-48GX-SFP

48-port 1000Mbps optical line card (EM4700BD-48GX-SFP) :implements 2-layer and 3-layer wire-speed switching and routing function of 48 1000Mbps optical interfaces, and IPv6 wire-speed transmission.

#### 1.4.2.11.1 Front Panel Diagram

EM4700BD-48GX-SFP provides 48 1000Mbps optical interfaces.

The following is the sketch map of its front panel:



Fig 1-18 the Sketch Map of the Front Panel of EM4700BD-48GX-SFP

The ports in the above chart are port GB1—GB48 from the bottom-left corner to the top-right corner. The indicator lamps of ports having odd index number are on the left side of the port array, while the indicator lamps of ports having even index number are on the right side. The lamps are green indicator lamps.

#### 1.4.2.11.2 Front Panel Indicator

The following is the instruction of the indicator lamps on the front panel of

Table 1.20 the Instruction of Indicator Lamps of EM4700BD-48GX-SFP

LED Indicator	Panel Sign	State	Explanation
SFP Interface Indicator Lamps			
State Indicator Lamp		On (green)	The network connection of SFP interface is normal.
		Off	There is no network connection on SFP interface
Transmission Indicator Lamp		On (green)	SFP is receiving or sending data.

### 1.4.2.11.3 Front Panel Interface Description

EM4700BD-48GX-SFP provides 48 SFP1000Mbps optical transceiver interfaces.

It supports the following kinds of SFP transceiver:

- ET4201-SX            Gigabit SFP MM 850 nm, 500m (SX)
- ET4201-LX           Gigabit SFP SM 1310 nm, 10Km (LX)
- ET4201-LHX         Gigabit SFP SM 1310 nm, 40Km (LHX)
- ET4201-ZX           Gigabit SFP SM 1550 nm, 80Km (ZX)
- ET4201-RJ45         Gigabit SFP to Copper cable RJ45

### 1.4.2.12 EM4700BD-4XG-XFP

EM4700BD-4XG-XFP implements 2-layer and 3-layer wire-speed switching and routing function of 4 10,000 Mbps XFP interfaces and IPv6 wire-speed transmission.

#### 1.4.2.12.1 Front Panel Diagram

The following is the sketch map of its front panel:



Fig 1-19 the Sketch Map of the Front Panel of EM4700BD-4XG-XFP

#### 1.4.2.12.2 Front Panel Indicator

The following is the instruction of the indicator lamps on the front panel of EM4700BD-4XG-XFP

Table 1.21 the Instruction of Indicator Lamps of EM4700BD-4XG-XFP

LED Indicator	Panel Sign	State	Explanation
Power Indicator Lamp	PWR	On (green)	The boardcard is power-on
		Off	The boardcard is power-off
Run Operating normally	RUN	On (green, glittering at the frequency of 1 HZ)	The boardcard is operating normally
		On (green, glittering at the frequency of 8 HZ)	The system is booting (Booting after the boardcard is hot-plugged in)
		Off	The boardcard is operating abnormally
XFP Interface Indicator Lamps			
State Indicator Lamp	Link	On (green)	The network connection of XFP Transceiver is normal.
		Off	There is no network connection on XFP Transceiver
Transmission Indicator Lamp	Act	On (green)	Receiving or sending data.

### 1.4.2.12.3 Front Panel Interfaces Description

EM4700BD-4XG-XFP provides 4 10,000 Mbps XFP electric interfaces.

EM4700BD-4XG-XFP supports XFP transceivers of the following types:

- ET5302-LR            XFP 10G Transceiver 10KM
- ET5302-ER            XFP 10G Transceiver 40km

## 1.4.3 Power supply

### 1.4.3.1 EM4704BD-AC

ES4704BD uses 1 +1 redundant power supplies. Each of them may serve as a standby power supply for another. Under normal operation conditions, the two power supply modules concurrently operate and each of them bears half of the loads. If one of the power supply modules fails to work or its switch is off, its alarming indicator will be on.

At the same time, another power supply becomes responsible for the power supply of the whole switch. When the failure power supply module returns to normal state or its switch is turned on, the alarming indicator will be off.

The power supply modules are installed on the upper part of the machine chassis, and are connected with the backplane of the switch through specific interfaces. The two power supply modules are fixed on the machine chassis with two screws. Each power supply module has one switch. Under normal operation conditions, two switches shall be turned on. For changing power supply modules, it is not necessary to open the chassis. You may turn off the switches of corresponding power supply modules and screwing off the fixing screws for changing the modules.

### 1.4.3.1.1 EM4704BD-AC (Alternating Current Power Module)

When powered by AC inputs, the AC power module EM4704BD-AC and corresponding AC distribution box should be used in the ES4704BD. The input voltage of the EM4704BD-AC is 90V/264 VAC, with ranges between 90 ~ 264 VAC and frequency between 50 ~ 60 Hz, the maximum output power is 400W.

### 1.4.3.1.2 Power module Front Panel

The front panel of EM4704BD-AC is equipped with power supply switches, power supply indicators as well as ventilating and cooling port and a handle for inserting and pulling out the modules.

The Front Panel view is shown below:

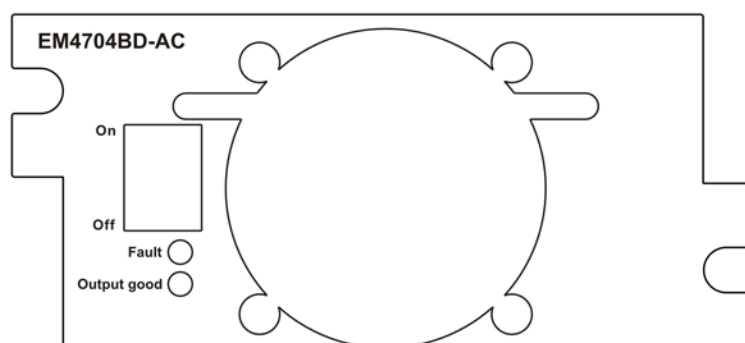

Fig 1-20 EM4704BD-AC Front Panel View

### 1.4.3.1.3 LED

The LED description of EM4704BD-AC is as follows

Table 1.22 The Description of EM4704BD-AC LED

LED	Panel	Status	Description
-----	-------	--------	-------------

	Label		
Output LED	Output Good	On Green	Power Module Output Status is okay
		Off	Power Module has no output
Abort LED	Fault	On Yellow	Faulty Power Module /Not turning-on The Output Switch
		Off	Power Module Working Fine

#### 1.4.3.1.4 Switch of power supply for front panel

EM4704BD-AC provides a power supply for controlling the power output of control module. Under normal operation conditions, the switches for power supply modules shall be turned on concurrently. When the switch of one power supply module is turned on and another is turned off, the FAULT indicator of the module will be on to suggest the users to turn on the switch so as to utilize 1+1 redundant backup.

#### 1.4.3.2 EM4710BD-AC

ES4710BD uses 2 +1 redundant power supplies, three power modules can act as backups for each other. During normal operation, all three power modules each take one third of the load. If one of the modules fails or is not present, the other two power modules will supply power for the whole switch, and the corresponding POWER/Fail warning indicator for the failed/missing module will illuminate, prompting the replacement of the failed module. The warning indicator will turn off after the failed module is replaced or recovers.

The ES4710BD power module is installed in the lower section of the chassis, and connects to the power board of the switch. All the power modules attach to the chassis with 2 screws, respectively. When replacing the power modules, the chassis need not to be opened, just remove the 2 fastening screws to take out the power module requiring replacement.

##### 1.4.3.2.1 EM4710BD-AC (Alternating Current Power Module)

When powered by AC inputs, the AC power module EM4710BD-AC and corresponding AC distribution box should be used in the ES4710BD. The input voltage of the EM4710BD-AC is 110V/220 VAC, with ranges between 90 ~ 264 VAC and frequency between 50 ~ 60 Hz, the maximum output power is 600W.

##### 1.4.3.2.2 Power module Front Panel

There are vents (with dust gauzes), 2 fastening screws and handle for replacing the modules on the front panels of EM4710BD-AC.

The Front Panel view is shown below:

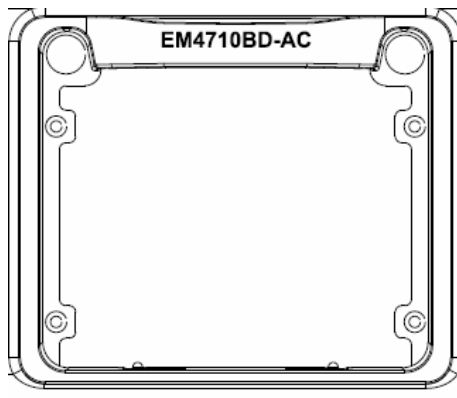

Fig 1-21 EM4710BD-AC Front Panel view

## 1.4.4 Power Distribution Box

### 1.4.4.1 ES4704BD Power Distribution Box

There is a special A.C. distribution box on the backboard of ES4704BD switch.

In generally, the enterprises users usually ask for the 90~264VAC access. The panel of A.C. distribution box is equipped with a 90~264VAC socket for provide power supply to the equipment. At the same time, it provides power supply to the two power supply modules. After the D.C. output is disposed on the backplane, it provides power supply to the modules and fan tray. The lower part of the power supply socket is equipped with a locking ring, which is used to fix the power supply lines to prevent unexpected disconnection and make the wiring more convenient. The distribution box is equipped with a grounding terminal at its lower right part, which is used for grounding the switch..

The Front Panel view is shown below:

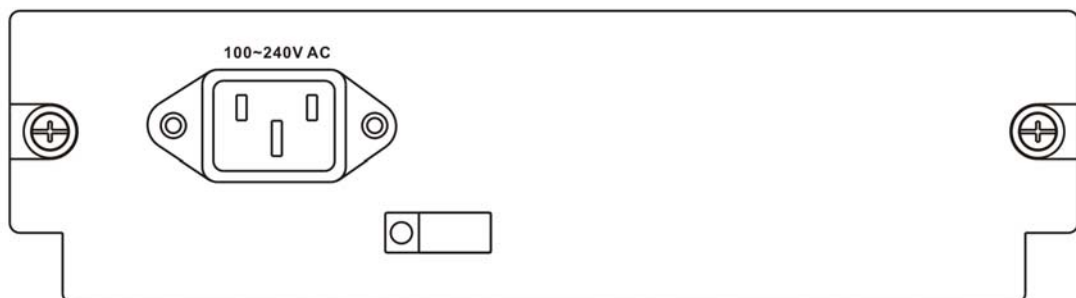

Fig 1-22 EM4704BD Power Distribution Box Panel view

### 1.4.4.2 ES4710BD Power Distribution Box

---

There is a dedicated AC distribution box in the lower section of ES4710BD backplane, distributing power supply for the corresponding AC power module. A grounding post is provided on the chassis on both sides of the distribution box for switch grounding. There is also an extraction handle, which is intended for the installation and removal of the distribution box only. **Never lift or move the switch with this handle!**

### 1.4.4.2.1 AC Power Distribution Box

Enterprise network users usually require equipment to have 220 VAC input, the AC power modules and AC distribution box can satisfy this application. Three 220V/110 VAC power input sockets are provided on the panel of the ES4710BD AC distribution box. Input AC power will first pass through protective circuits, such as the AC filter, lightning protection tube, and then provide power for the three AC power modules. The other modules and fan trays are powered only after the DC output from the power modules are equalized and coupled. A wiring clip is provided above each 220V/110 VAC input socket for the positioning of power cords and easier wiring. In addition, on the left side of the AC distribution panel is a power supply switch used to control the modules' power output . Please turn this power supply switch on during normal operation of the ES4710BD.

The Front Panel view is shown below:

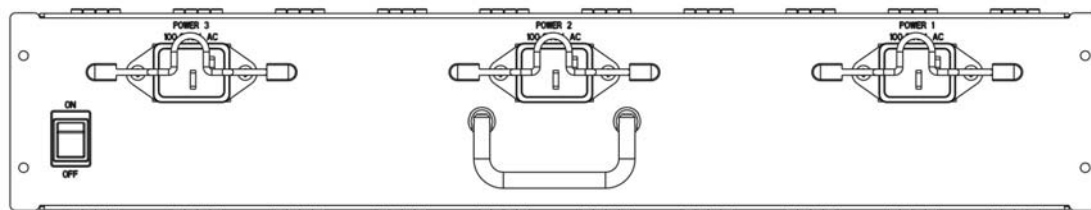

Fig 1-23 ES4710BD AC Power Distribution Box

## 1.4.5 System Backplane

The system board of ES4704BD series switch is located inside the switch, providing interconnectivity in the high speed data links between management switching modules, network interface modules and between all management and control signals of various cards. A backplane has been installed in the unit chassis. The backplane provides the following functions:

- Provides communication channel for cards to achieve interconnectivity of various signals
- The backplane is powerless
- Supports the hot-swapping of various cards
- Supports Mainboard Master-Slave swap
- Auto identification of all slots
- Distributed power supplies
- Introduction of monitoring signals for fans and power supplies

---

## 1.4.6 Fan Tray

### 1.4.6.1 ES4704BD Fan Tray

Three fan assemblies (EM4704BD-FAN) can be configured in the ES4704BD, and installed in a horizontal configuration into the fan module slots in the switch's upper front panel. The three fan assemblies cover the entire board area, ensuring sufficient ventilation for the devices, hence enhancing the stability of devices even under high temperature environments. Each fan assembly consists of 2 axial fans, which are protected by the fan tray to prevent bodily injury. Please note that the fan blades still spin at a high speed when disconnected from the device during operation, to avoid bodily injury **do not** touch the spinning blades.

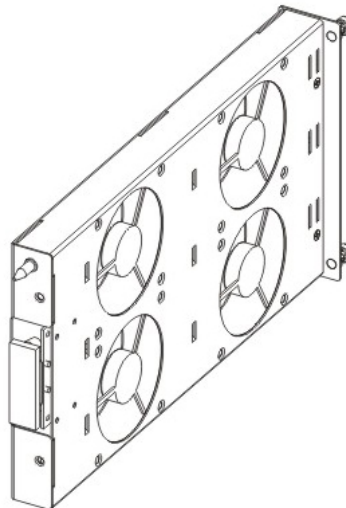

Fig 1-24 EM4704BD-FAN Outlook

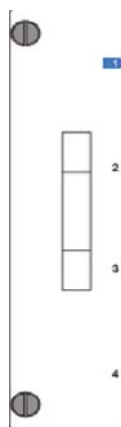

Fig 1-25 EM4704BD-FAN Front Panel View



---

## 1.4.6.2 ES4710BD Fan Tray

Three fan assemblies (EM4710BD-FAN) can be configured in the ES4710BD, and installed in a horizontal configuration into the fan module slots in the switch's upper front panel. The three fan assemblies cover the entire board area, ensuring sufficient ventilation for the devices, hence enhancing the stability of devices even under high temperature environments. Each fan assembly consists of 2 axial fans, which are protected by the fan tray to prevent bodily injury. Please note that the fan blades still spin at a high speed when disconnected from the device during operation, to avoid bodily injury **do not** touch the spinning blades.

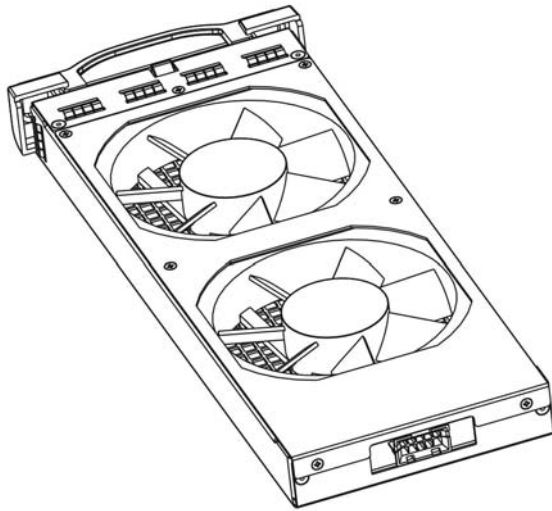

Fig 1-26 EM4704BD-FAN Outlook

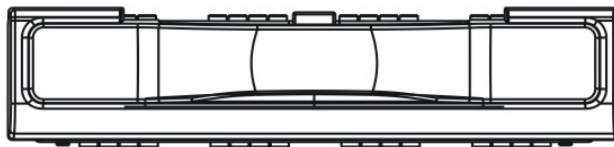

Fig 1-27 EM4704BD-FAN Front Panel View

## 1.4.7 Dust Gauze

### 1.4.7.1 ES4704BD Dust Gauze

The ES4704BD's dust gauze lies under the board rack and prevents large particles in the air from entering the switch. The dust gauze should be inserted from the front of the

---

ES4704BD in a horizontal position.

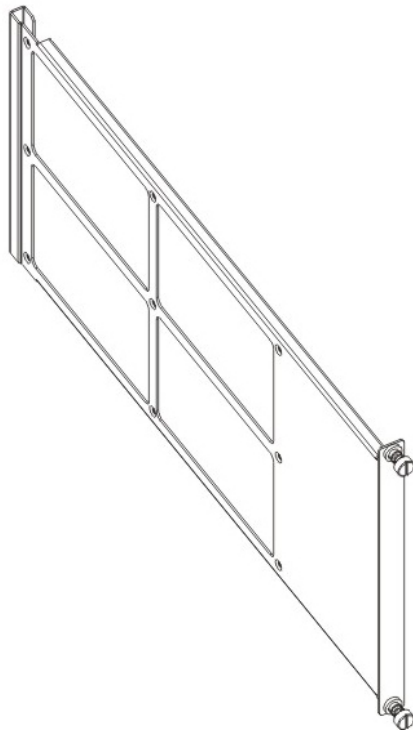

Fig 1-28 EM4704BD Dust Gauze Outlook

### 1.4.7.2 ES4710BD Dust Gauze

The ES4710BD's dust gauze lies under the board rack and prevents large particles in the air from entering the switch. The dust gauze should be inserted from the front of the ES4710BD in a horizontal position.

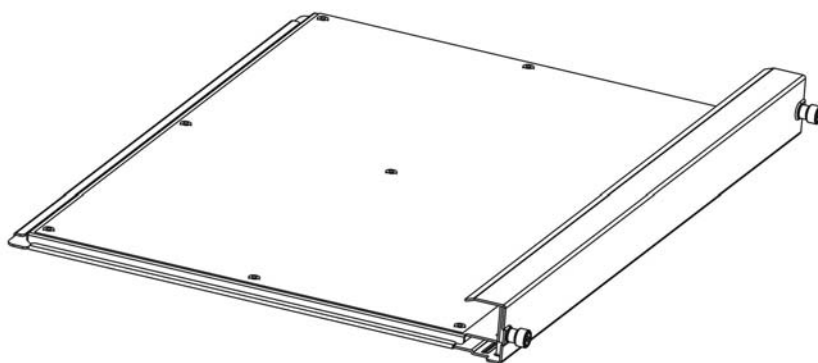

Fig 1-29 EM4704BD Dust Gauze Outlook

### 1.4.8 Rear Panel

---

### 1.4.8.1 ES4704BD Rear Panel

The rear panel of the ES4704BD covers the switch backplane. To ensure safe operation of the switch, please do not open the rear panel. There are two reversible handles on the rear panel, they are used only for the installation and removal of the rear panel. Never lift or move the switch with these handles! The rear panel is shown below:

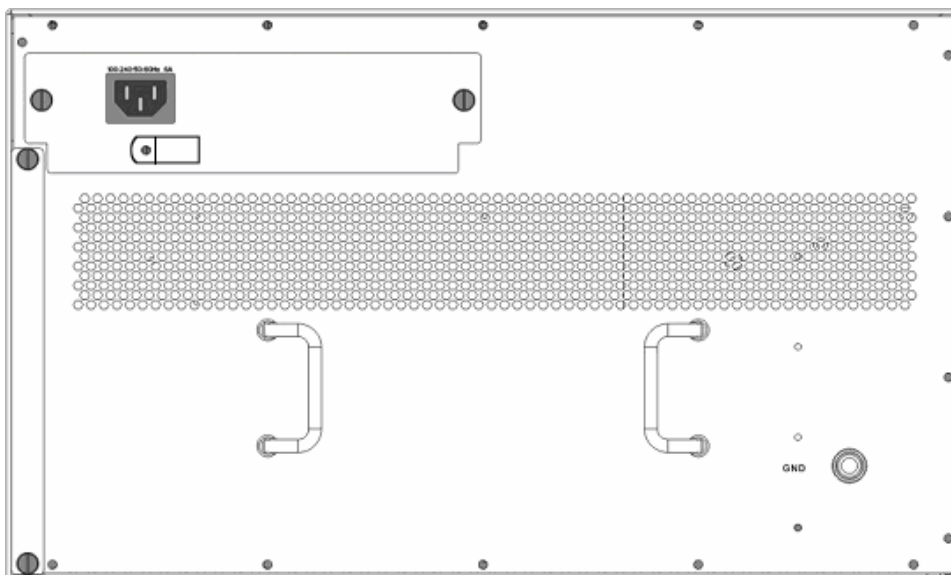

FIG 1-30 ES4704BD Rear Panel View

### 1.4.8.2 ES4710BD Rear Panel

The rear panel of the ES4710BD covers the switch backplane. To ensure safe operation of the switch, please **do not** open the rear panel. There are two reversible handles on the rear panel, they are used only for the installation and removal of the rear panel. Never lift or move the switch with these handles! The rear panel is shown below:

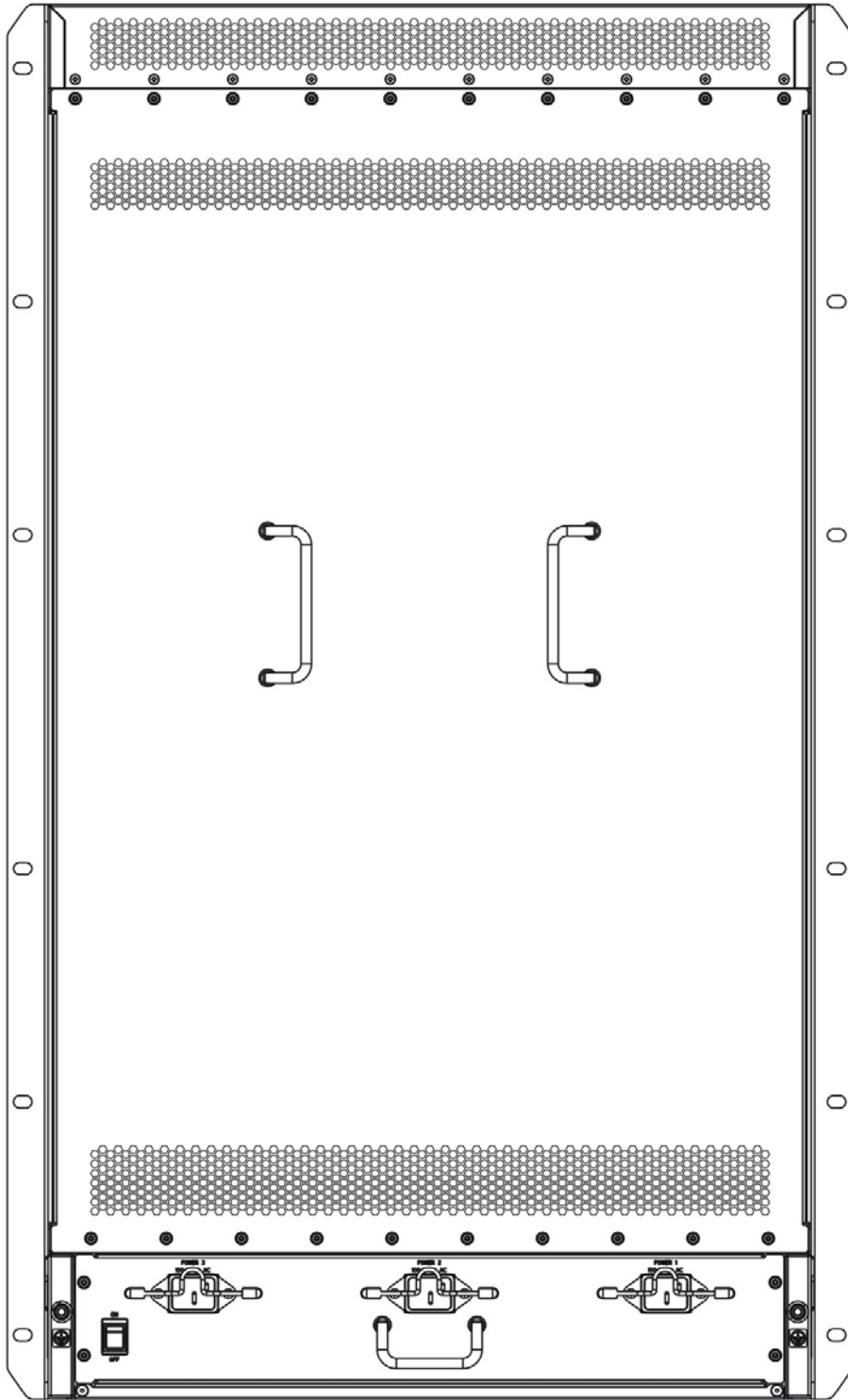

FIG 1-31 ES4710BD Rear Panel View

## 1.4.9 Side Panels

---

### 1.4.9.1 ES4704BD Side Panels

There are several rows of ventilation openings in the left and right sides of the switch, as shown above.

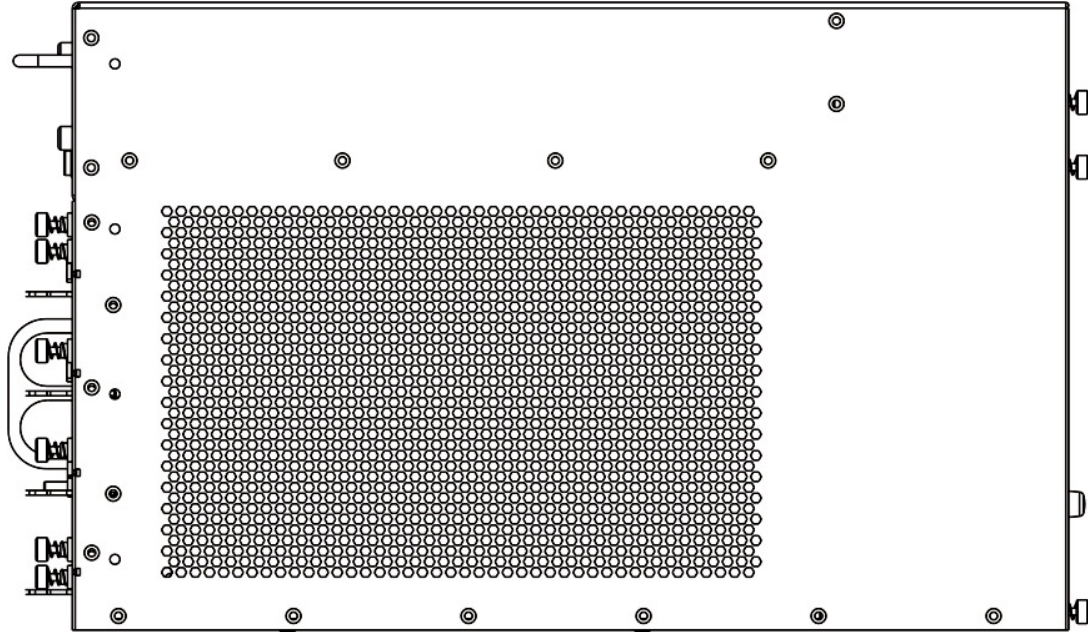

FIG 1-32 ES4704BD Side Panels View

Please do not block the ventilation openings and ensure that enough clearance is left on both sides of the switch for air circulation. Failure to do so can cause the chassis to overheat and the system to fail, or damage to components.

### 1.4.9.2 ES4710BD Side Panels

There are several rows of ventilation openings in the left and right sides of the switch, as shown above.

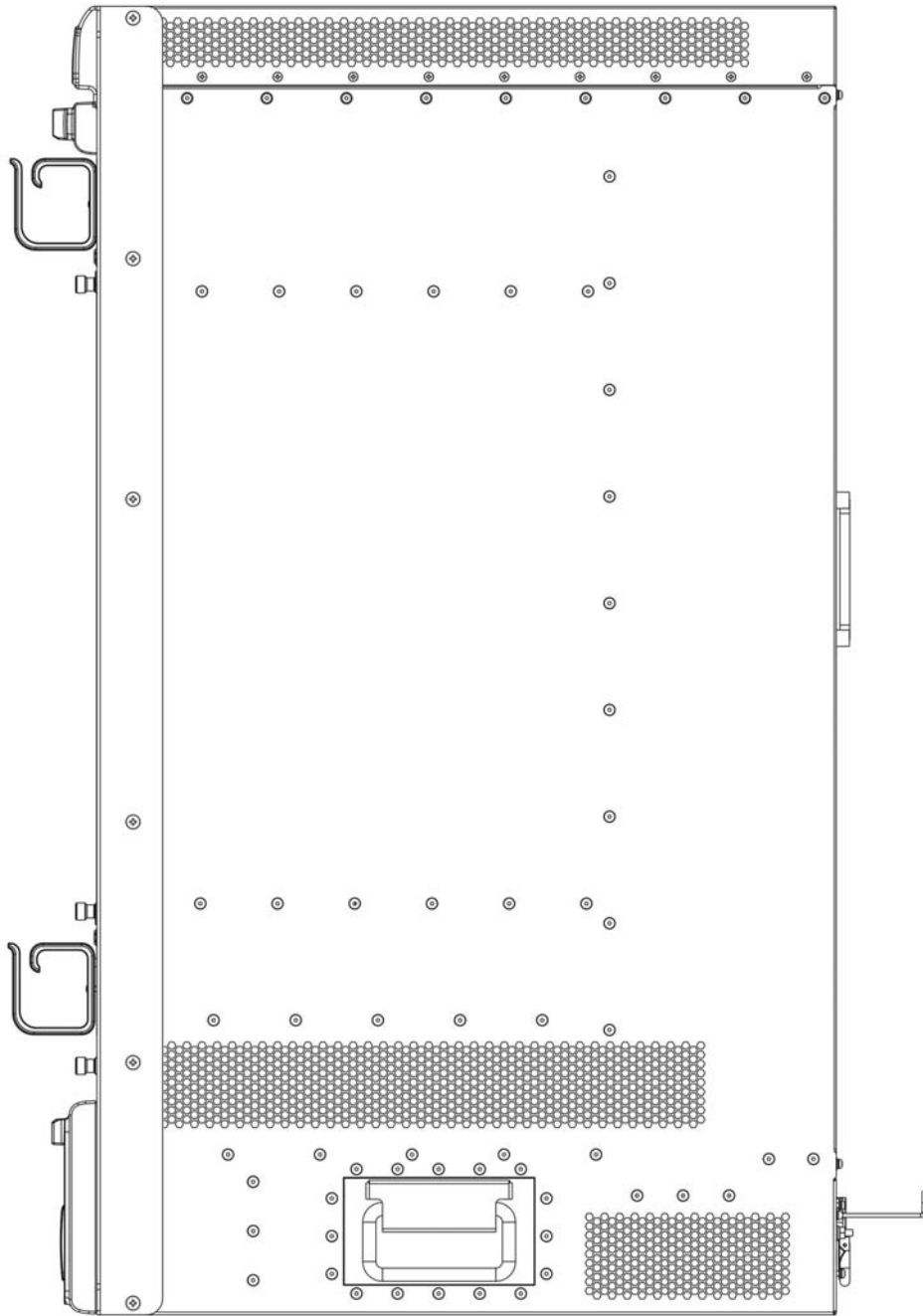

FIG 1-33 ES4710BD Side Panels View

Please do not block the ventilation openings and ensure that enough clearance is left on both sides of the switch for air circulation. Failure to do so can cause the chassis to overheat and the system to fail, or damage to components.

## 1.5 System Features

### 1.5.1 ES4704BD System Features

The ES4704BD Switch system features are described in the table below.

Table 1.23 ES4704BD System Features (1)

SDRAM	128MB
FLASH	32MB
Status indicator:	Port: Traffic, LINK General: Power status, system status, hot-swap indicator
Weight	30KG (Max full configuration weight)
Physical Dimensions	440mm x266mm x421mm (W x H x D)
Relative humidity	10% ~ 90% with no condensing
Operating Temperature	0°C ~ 40°C
Power Supplies	Nominal Input Voltage AC: 90 ~ 264 VAC, 50 ~ 60Hz (supporting 1+1 redundant backup of power modules)
Power Consumption	≤ 400 W
Forwarding Mode	Store-and-forward

Table 1.24 ES4704BD System Features(2)

Property	Specification
Basic Configuration	4 slots
Hot swap	Yes
Failover design	Core part redundant hot swapping
	Power supplies redundant hot swappable

## 1.5.2 ES4710BD System Features

Table 1.25 ES4710BD System Features

SDRAM	128MB
FLASH	32MB
Status indicator:	Port: Traffic, LINK General: Power status, system status, hot-swap indicator

Weight	65KG (Max full configuration weight)
Physical Dimensions	436mm x 797mm x 478mm (W x H x D)
Relative humidity	10% ~ 90% with no condensing
Operating Temperature	0°C ~ 40°C
Power Supplies	Nominal Input Voltage AC: 90 ~ 264 VAC, 50 ~ 60Hz (supporting 2+1 redundant backup of power modules)
Power Consumption	≤ 1200 W
Forwarding Mode	Store-and-forward

The ES4710BD Switch system features are described in the table below.

Table 1.26 ES4710BD System Features

Property	Specification
Basic Configuration	10 slots
Hot swap	Yes
Failover design	Core part redundant hot swapping
	Power supplies redundant hot swappable



---

# Chapter 2 Hardware Installation

During the installation and use of the ES4704BD Switch, please follow the safety guidelines listed below:

## Basic Guidelines

1. Disconnect power supplies from the chassis before disassembly or moving the switch.
2. Install the switch in a clean area, ensuring proper temperature and humidity conditions.
3. Keep the device accessories in a safe place.
4. When handling modules, always handle the modules by the edge, avoid contact with integrated components and printed circuits.
5. Prevent electrostatic discharge damage to the integrated components and printed circuits.
6. Keep maintenance tools in a safe place.
7. Do not wear loose clothing that may catch on devices, also remember to fasten ties or scarves and roll up your sleeves.
8. If the environment may cause harm to eyes, be sure to wear a pair of protective goggles.
9. Do not perform any operation that may result in bodily injury or damage to the device.
10. When cleaning the switch, do not use a damp cloth to wipe the switch and never wash the switch with liquids.

## Safety Warning

1. Safety warnings appear throughout this publication, referring to operations **that may harm you if performed incorrectly**.
2. Read through the installation instruction carefully before operating the system.
3. Only trained and qualified personnel should be allowed to install, replace, or service the switch.
4. Disconnect power supplies from the chassis before disassembly or moving the switch.
5. The final configuration of the product must abide by all national laws and codes.

## Hot Line Work Safety Guidelines

1. Before working on equipment that is connected to power lines, remove jewelry (including rings, necklaces, watches and bracelets).
2. Metal objects will cause short circuits and damage the device when in contact with both powered items and the ground.
3. An improper connection between the device and power sockets may be

---

hazardous.

4. Only trained and qualified personnel should be allowed to operate and maintain the device.
5. Reading through the installation guidelines before powering on the system.

---

### Notice

! Watch out for potential dangers, e.g. wet floors, ungrounded power lines, and worn power lines.

! Have an emergency switch installed inside the workshop, so that power can be cut off promptly should an accident occur.

! Do not work alone if potential dangers are present.

! On the event of an accident, take the following measures:

1. Power down the system
  2. Make emergency calls if required
  3. Determine whether the victim requires immediate treatment and take appropriate action
  4. If possible, send someone for medical help; otherwise, consider the damage and seek help
- 

## 2.1 Basic Requirements

### 2.1.1 Site Requirements

The ES4700BD Switch must be used indoors, and have the following requirements:

Ambient temperature: 0 ~ 40°C

Humidity: 10% ~ 90%, non-condensing

The ES4700BD is equipped with a fan assembly for providing the switch with an appropriate level of cooling; you can place the switch on a workbench or rack. Ensure the following:

- The rack or workbench should be well ventilated. For sufficient air circulation, it is recommended to mount the switch on a 19" standard rack with sufficient spacing. Air conditioning is recommended in areas with high temperatures in the summer.
- To cool the internal circuits, the switch comes with internal fan assemblies. To maintain proper air circulation through the switch chassis, we recommend that you maintain a minimum 100mm separation between the chassis air intake or the chassis air exhaust and any walls. Make sure that all air intakes and exhausts on the system remain unobstructed. Do not stack heavy items on the switch.
- Make sure the rack or workbench are strong enough to support the weight of a fully configured switch.

- Make sure the rack or workbench is well grounded; if the workbench is not grounded, it should be placed near a grounding conductor to provide easy ground connection for the switch.

## 2.1.2 Temperature and Humidity Requirements

To maximize the switch's performance and lifespan, the site should maintain a desirable temperature and humidity. High-humidity conditions can cause electrical resistance degradation or even electric leakage, degradation of mechanical properties and corrosion of internal components. Extreme low relative humidity may cause the insulation spacer to contract, making the fastening screw insecure. Furthermore, in dry environments, static electricity is liable to be produced and cause harm to internal circuits. Temperature extremes can cause reduced reliability and premature aging of insulation materials, thus reducing the switch's working lifespan. The recommended temperature and humidity are shown below:

Temperature:		Relative humidity	
Long term condition	Short term condition	Long term condition	Short term condition
15 ~ 30°C	0 ~ 40°C	40~65%	10~90%

### Notice

A sample of ambient temperature and humidity should be taken at 1.5m above the floor and 0.4m in front of the switch rack, with no protective panel covering the front and rear of the rack.

Short term working conditions refer to a maximum of 48 hours of continued operation and an annual cumulative total of less than 15 days.

Formidable operation conditions refers to the ambient temperature and relative humidity value that may occur during an air-conditioning system failure, and normal operation conditions should be recovered within 5 hours.

## 2.1.3 Dust and Particles

Dust is harmful to the safe operation of the ES4700BD. Dust can lead to electrostatic adherence, especially likely under low relative humidity, causing poor contact of metal connectors or contacts. Electrostatic adherence will result in not only reduced product lifespan, but also increased chance of communication failures. The recommended values for dust content and particle diameter in the site are shown below:

Max. Diameter ( $\mu\text{m}$ )	0.5	1	3	5
Max. Density (particles/ $\text{m}^3$ )	$1.4 \times 10^7$	$7 \times 10^5$	$2.4 \times 10^5$	$1.3 \times 10^5$

In addition, salt, acid and sulfide in the air are also harmful to the switch. Such harmful gases will aggravate metal corrosion and the aging of some parts. The chosen site should avoid harmful gases, such as  $\text{SO}_2$ ,  $\text{H}_2\text{S}$ ,  $\text{NO}_2$ ,  $\text{NH}_3$  and  $\text{Cl}_2$ , etc. The table below details the threshold values.

Gas	Average ( $\text{mg}/\text{m}^3$ )	Max ( $\text{mg}/\text{m}^3$ )
$\text{SO}_2$	0.2	1.5
$\text{H}_2\text{S}$	0.006	0.03
$\text{NO}_2$	0.04	0.15
$\text{NH}_3$	0.05	0.15
$\text{Cl}_2$	0.01	0.3

## 2.1.4 Preventing Electrostatic Discharge Damage

Static electric discharges can cause damage to internal circuits, even the entire switch. Follow these guidelines for preventing ESD damage:

1. Ensure proper earth grounding of the device
2. Perform regular cleaning to reduce dust
3. Maintain proper temperature and humidity
4. Always wear an ESD wrist strap and antistatic uniform when in contact with circuit boards

## 2.1.5 Anti-interference Requirements

All sources of interference, whether from the device/system itself or the outside environment, will affect operations in various ways, such as capacitive coupling, inductive coupling, electromagnetic radiation, common impedance (including the grounding system) and cables/lines ( power cables, signal lines, and output lines). The following should be noted:

1. Precautions should be taken to prevent power source interruptions
2. Provide the system with a dedicated grounding, rather than sharing the grounding with electronic equipment or lightning protection devices

- 
3. Keep away from high power radio transmitters, radar transmitters, and high frequency strong circuit devices
  4. Provide electromagnetic shielding if necessary

## 2.1.6 Rack Configuration

The dimensions of the ES4704BD are designed to be mounted on a standard 6" rack, the dimensions are 440mm x 266mm x 421mm (W x H x D). The dimensions of the ES4710BD are designed to be mounted on a standard 19" rack, the dimensions are 436mm x 797mm x 478mm (W x H x D). Please ensure good ventilation for the rack.

- Every device in the rack will generate heat during operation, therefore vent and fans must be provided for an enclosed rack, and devices should not be stacked closely,.
- When mounting devices in an open rack, care should be taken to prevent the rack frame from obstructing the switch ventilation openings. Be sure to check the positioning of the switch after installation to avoid the aforementioned.

---

### Notice

If a standard 19" rack is not available, the ES4700BD can be placed on a clean level desktop, leave a clearance of 100mm around the switch for ventilation, and do not place anything on top of the switch.

---

## 2.1.7 Power Supply Requirements

The ES4704BD is designed to use modular switching power supplies, supporting 1 +1 redundant backup of power modules. The power input specification is shown below:

Nominal Input Voltage

AC: 90 ~ 264 VAC, 50 ~ 60Hz

Total power consumption: ≤400W

The ES4710BD is designed to use modular switching power supplies, supporting 2 +1 redundant backup of power modules. The power input specification is shown below:

Nominal Input Voltage

AC: 90 ~ 264 VAC, 50 ~ 60Hz

Total power consumption: ≤1200W

Before installing the power modules, please check the power input to ensure proper grounding of the power supply system. The input source for the switch should be reliable and secure, a voltage adaptor can be used if necessary. The building's circuit protection

---

system should include in a fuse or circuit-breaker of no greater than 240V, 10A. It is recommended to use a UPS for more reliable power supply.

---

 **Notice**

Improper power supply system grounding, extreme fluctuation of the input source, and transients (or spikes) can result in larger error rate, or even hardware damage.

---

## 2.2 Preparing for Installation

After verifying site requirements, please check the contents of the switch container and accessory kit. (If you are concerned that any item is missing or an incorrect item has been supplied, please contact your dealer as soon as possible.)

### 2.2.1 Checking Switch Hardware Configuration and Accessories

After verifying site requirements, you can now unpack the shipping container to verify the switch configuration and contents of the accessory kit.

A basic configuration ES4704BD should include the following:

ITEM No.	Part name	Number	Memo
1	ES4704BD Ethernet Switch	1	
2	AC cable	3	
3	Serial port cable	1	
4	Grounding cord	1	
5	Chassis hanger	2	
6	Hanger screw	8	
7	Rack screw	8	
8	Manual CD	1	
9	Qualification certificate	1	
10	Warranty card	1	

A basic configuration ES4710BD should include the following:

ITEM No.	Part name	Number	Memo
1	ES4710BD Ethernet Switch	1	
2	AC cable	3	
3	Serial port cable	1	
4	Grounding cord	1	
5	Chassis hanger	2	
6	Hanger screw	12	
8	Manual CD	1	
9	Qualification certificate	1	
10	Warranty card	1	

Note: The above list is subject to change without notice, please use the packing list shipped with the switch as the checklist.

## 2.2.2 Required Tools and Utilities

Required tools	● cross screwdrivers
	● Flat-blade screwdriver
	● ESD-preventive wrist strap
Connection cables	● Serial port cable
	● Multi-mode fiber cable
	● Single-mode fiber cable
	● Category 5 cable with RJ-45 connector

## 2.3 Hardware Installation

The installation of the ES4704BD includes the following:

- ☞ Switch mounting
  - Desktop installation
  - Rack-mounting the switch
- ☞ Switch grounding
- ☞ Cards and modules installation
- ☞ Connecting to the Console
  - Connecting to the Console port

- 
- ☞ Connecting to the Management Port
    - Connecting to the Ethernet port
  - ☞ SFP transceiver installation
    - Install the SFP transceiver in the SFP slot
  - ☞ XENPAK transceiver installation
    - Install the XENPAK transceiver in the XENPAK slot
    - Copper Cable/Fiber cable connection
    - Ethernet cable connection
    - Fiber cable connection
  - ☞ Power supply connection

## 2.3.1 Switch Installation

### 2.3.1.1 Desktop installation

- **Note:**
  - Choose a smooth level workbench
  - Verify that the workbench is strong enough to support the ES4704BD's fully configured weight
  - Plan a good position for your ES4704BD that is easy to operate and has an appropriate power source and grounding point.
  - Place the ES4704BD safely on the workbench, avoid obstructions on any side of the switch.

---

 **Notice**

To avoid damage, do not place any weight on the switch.

### 2.3.1.2 Rack-mounting ES4700BD

- **Note:**

Before mounting the ES4700BD into the rack, verify that the mounting positions of the rack are correct. Preposition of the mounting points may result in inadequate spacing between the switch front panel and the rack front door, and the rack front door may be unable to be closed with cables and fiber cables connected. Please keep a 10 mm spacing between the switch front panel and the rack front door.

Verify the following before installation: the rack is stably positioned; all modules inside the chassis are fully installed; no obstructions are present inside or around the rack; the switch is situated near the rack for ease of installation.



---

- **Installation Steps**

Step 1: Attach the 2 hangers on the ES4700BD with screws provided in the accessory kit.

Be sure to attach the hangers in the correct direction, otherwise the switch will not be able to mount into a standard rack.

Note that the hangers are not weight bearing. They are used to fasten the switch. The mounting Shelf or sliding rails (bolt to the rack) will support the switch.

The figure below shows the steps for mounting the hangers:

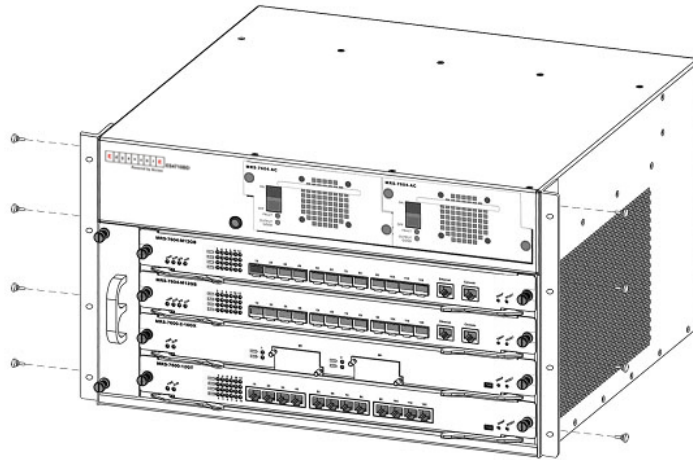

Fig 2-1 Installing ES4704BD Switch Hangers

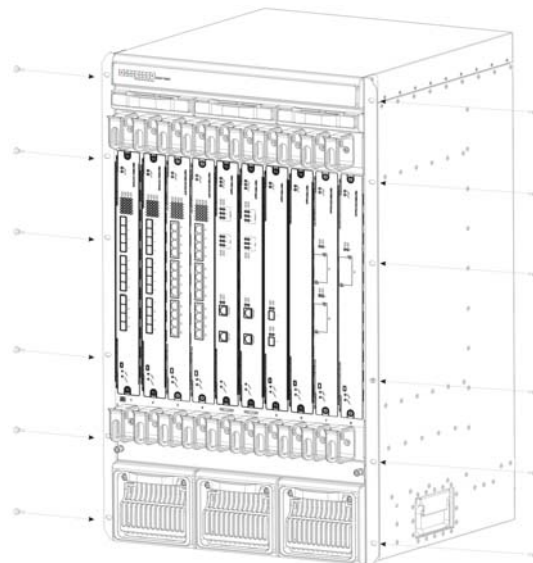

Fig 2-2 Installing ES4710BD Switch Hangers

---

Step 2: Put the hanger-mounted switch smoothly into a standard 6" rack.

Because of the size and weight of a ES4700BD, 2 people are required to complete the installation. With a person standing on each side of the chassis, grasp the chassis handle in the lower side panel with one hand, and use the other hand near the top of the chassis for balance. Slowly lift the chassis in unison and carry it to the rack. Lift the ES4700BD to a position a little higher than the mounting shelf or sliding rails, resting the chassis on the shelf/rails, and then carefully slide the chassis into the rack. Be sure to align the hangers and mounting holes in the rack column.

Step 3: Fasten the ES4700BD to the rack with the screws provided.

Bolt the hangers to the matching holes in the rack column with the screws provided. Be sure to tighten the screws smoothly. The ES4700BD should now be securely attached to the equipment rack.

The procedure is shown below:

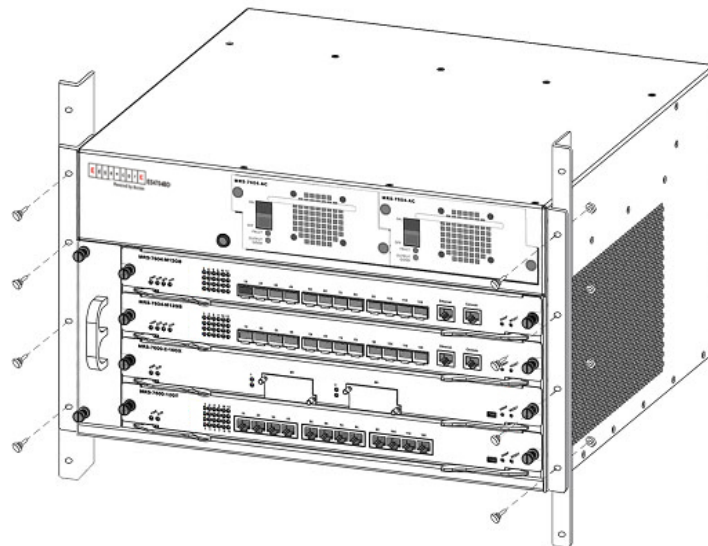

Fig 2-3 Rack-mounting ES4704BD

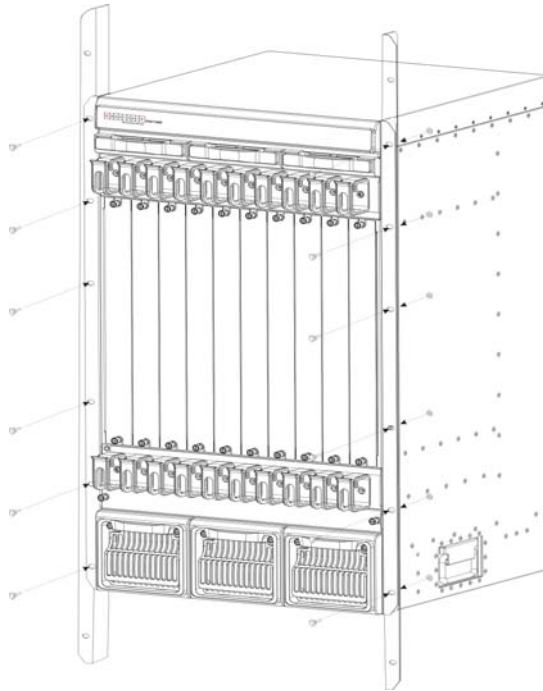

Fig 2-4 Rack-mounting ES4710BD

### 2.3.1.3 Wearing an ESD Wrist Strap

An ESD Wrist Strap must be worn during the installation of the switch. To prevent any damage occurring to the device, avoid contact between the printed circuit boards and your clothing. Avoid bodily contact with components on the circuit boards if possible.

To wear an ESD Wrist Strap:

- Step 1: place your hand into the ESD wrist strap
- Step 2: tighten the fastener and ensure that it makes maximum contact with the skin
- Step 3: Insert the equipment end of the strap into the antistatic socket (indicated by an ESD symbol) in the switch front panel

### 2.3.2 Switch grounding

A good grounding system is the groundwork for the smooth and safe operation of the ES4700BD, and an excellent way to prevent lightning strikes and resistance interference. Please follow the switch grounding specification instructions, verify the installation site's grounding condition and ensure proper grounding accordingly.

- **Proper grounding**

When using an AC power source, the device must be grounded with the green and yellow ground cables, otherwise, shock hazards may occur when insulation resistance between the internal power supply and the chassis degrades.

---

- **Lightning protection grounding**

The lightning protection system is an independent system consisting of a lightning rod, conductor and connection joint with the grounding system. The grounding system usually is shared with the power reference grounding and green and yellow ground cable grounding. Lightning protection grounding is a building requirement, not a specific requirement of the switch.

- **Electromagnetic compliance grounding**

This refers to the grounding to comply with switch electromagnetic compatibility requirements, including shielded grounding, filter grounds, noise, and interference control and level reference. The overall grounding requirements are the sum total of the above. Ground resistance value should be less than 1 ohm.

The ES4700BD provides chassis grounding post in the lower rear chassis, marked as "GND". Chassis protection grounding should be properly connected to the rack grounding connector

The ground cabling procedures are listed below:

Step 1: remove the nuts from the rear chassis grounding posts

Step 2: wrap one end of the green and yellow grounding cable to the grounding posts

Step 3: attach the grounding post nut and tighten well

Step 4: attach the other end of the grounding cable to the rack grounding connector

Note:

- The grounding cable should be made of a good conductor, and the diameter should be determined by the possible maximum current that may pass through.
- Bare conductor cabling is forbidden.
- Ground resistance value: the combined grounding resistance should be less than 1 ohm.

## **2.3.3 Card and module installation**

The ES4700BD is a rack-mounting device, various cards and modules are available.

Basic configuration: chassis, power supply modules (optional 1 +1 redundant), system backplane, fan tray, dust gauze, distribution box. The above parts have been mounted upon shipment, please verify they are properly locked before installation.

### **2.3.3.1 Removing and Installing the Cards**

The installation procedure is the same for all cards, as shown below:

Step 1: Power down the switch (Hot-swapping is supported by optional cards for the

---

switch. However, for better convenience, it is recommended to power down the switch before installing the cards, if no module in the switch is running.)

Step 2: Ensure proper grounding of the switch

Step 3: Put on an ESD wrist strap before contact with the switch circuit, and make sure the ESD wrist strap is connected securely to the ESD connector in the switch's front panel.

Step 4: Loosen the panel fasteners locking back plate counterclockwise and remove the back plate.

Step 5: Insert the optional module into the slot, you can use the metal handle on the front plate of the module to ensure good contact. Then lock the module with panel fasteners in the front plate.

### 2.3.3.2 Removing and installing the Dust Gauze

Dust gauze is provided in the right section of the ES4700BD, which can be installed and removed from the back of the switch. The dust gauze is meant to prevent large debris or particles in the air from being ingested into the switch. Please perform cleaning on a regular basis according to the site conditions.

- Loosen the 2 panel fasteners in the dust gauze
- Draw the dust gauze out smoothly by holding the 2 screws
- Clean the dust gauze with a brush (never wash with any liquid)
- Insert the gauze back to its original position in the switch
- Tighten the panel fasteners.

Note: The dust gauze is installed on switch chassis shipment.  
The installation and removal of the dust gauze is shown below:

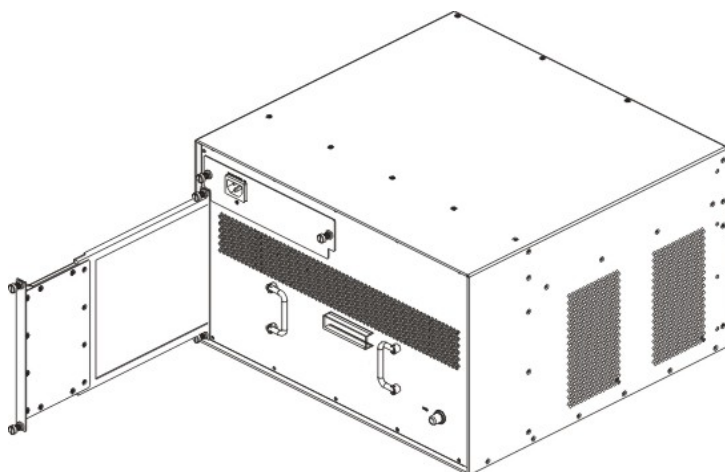

Fig 2-5 Installation and removal of the ES4704BD dust gauze

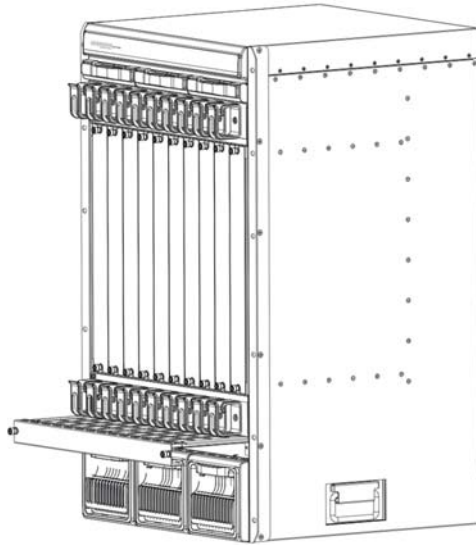

Fig 2-6 Installation and removal of the ES4710BD dust gauze

### **2.3.3.3 Removing and Installing the Fan Tray**

#### **2.3.3.3.1 Removing and Installing the ES4704BD Fan Tray**

The ES4704BD has two fan trays in the left section of the switch, and can be serviced from the front. The installation and removal of the fan tray is relatively simple. To install, just hold the fan tray in the correct direction, align with the corresponding slot and push to secure. Tighten the panel fasteners in the front panel. Upon removal, first loosen the 2 screws in the front panel of the fan tray, hold the handle in the front panel of fan tray with your middle and ring fingers, press the locker slightly down, and the fan tray can be drawn out smoothly.

Note: The fan trays are installed on switch chassis shipment.

The installation and removal of a fan tray is shown below:

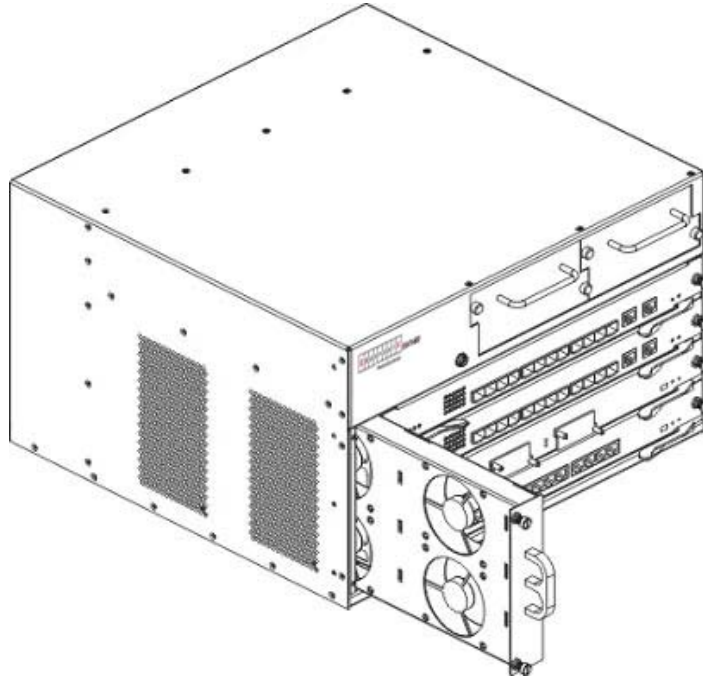

Fig 2-7 The installation and removal of ES4704BD fan tray

### **2.3.3.3.2 Removing and Installing the ES4710BD Fan Tray**

The ES4710BD has three fan trays in the upper section of the switch, and can be serviced from the front. The installation and removal of the fan tray is relatively simple. To install, just hold the fan tray in the correct direction, align with the corresponding slot and push to secure. The locker in the front panel of the fan tray will lock automatically. Upon removal, hold the handle in the front panel of fan tray with your middle and ring fingers, press the locker slightly down, and the fan tray can be drawn out smoothly.

Note: The fan trays are installed on switch chassis shipment.

The installation and removal of a fan tray is shown below:

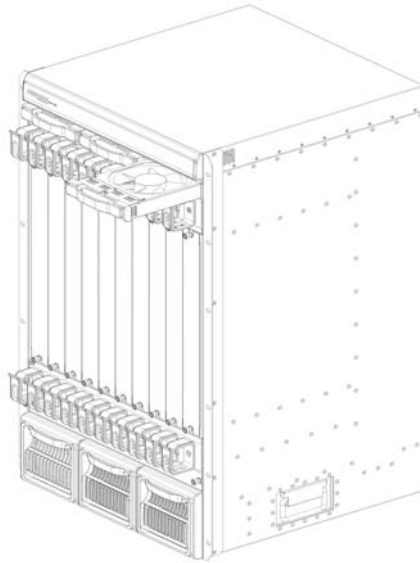

Fig 2-8 The installation and removal of ES4710BD fan tray

### **2.3.3.4 Removing and Installing Power Supply Modules**

#### **2.3.3.4.1 Removing and Installing ES4704BD Power Supply Modules**

The ES4704BD employs a 1 +1 redundant power supply module combination, all two modules will work during normal operation. In case one module fails, it can be replaced while the system is operating without presenting an electrical hazard or damage to the system. The procedures are provided below:

- Step 1: First, turn off the switch in the front panel of the power supply module to be replaced
- Step 2: Loosen the 2 panel fasteners in the front panel of the power supply module to be replaced by turning the screwdriver counter clockwise
- Step 3: Hold the handle in the upper front panel of the power supply module, and draw out the power supply module firmly and smoothly
- Step 4: Turn off the switch in the front panel of the new power supply module, use the new power supply module and replace the failed module . Tighten the panel fasteners in the front panel
- Step 5: Turn on the switch in the front panel of the power supply module, successful replacement will be indicated by the green OUTPUT GOOD indicator on the front panel of the power supply module being illuminated and by the yellow Fail indicator not illuminating.



---

Installation of a power supply module is shown below:

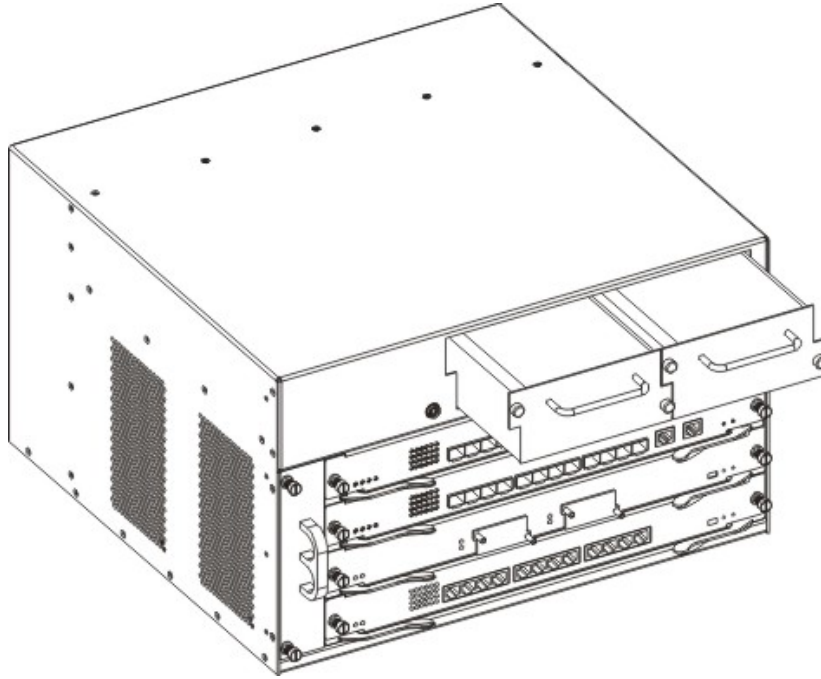

Fig 2-9 The installation and removal of ES4704BD power supply modules

### **2.3.3.4.2 Removing and Installing ES4710BD Power Supply Modules**

The ES4710BD employs a 2 +1 redundant power supply module combination, all three modules will work during normal operation. In case one module fails, it can be replaced while the system is operating without presenting an electrical hazard or damage to the system. The procedures are provided below:

- Step 1: Loosen the 2 panel fasteners in the front panel of the power supply module to be replaced by turning the screwdriver counter clockwise
- Step 2: hold the handle in the upper front panel of the power supply module, and draw out the power supply module firmly and smoothly
- Step 3: Use a new power supply module and replace the failed module
- Step 4: Tighten the panel fasteners in the front panel
- Step 5: Successful replacement will be indicated by the green Power OK indicator being illuminated and by the yellow Fail indicator not illuminating.

Installation of a power supply module is shown below:

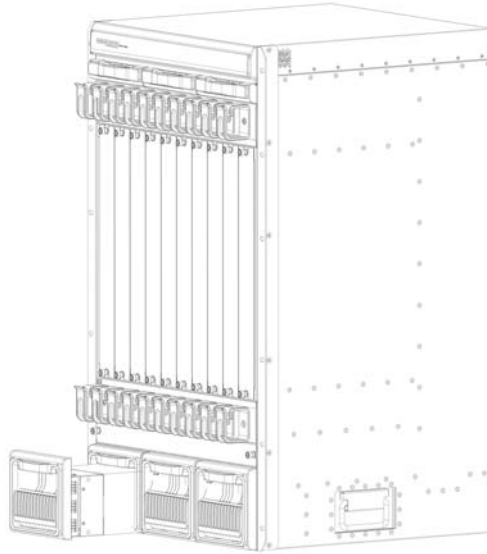

Fig 2-10 The installation and removal of ES4710BD power supply modules

- Clean power module dust gauze:

Power module dust gauze is provided in the front panel of the EM4710BD-AC power modules, which can be removed and installed easily. It can prevent large debris or particles in the air from being ingested into the power supply module. Please perform cleaning on a regular basis according to the site conditions.

- Pulling the lower dust gauze front panel, draw the dust gauze and front panel out
- Clean the dust gauze with a brush (never wash with any liquid)
- Insert the gauze back to its original position in the power supply module
- Push dust gauze and front panel back to power module
- Press the lower dust gauze front panel and lock it

The installation and removal of the dust gauze is shown below:

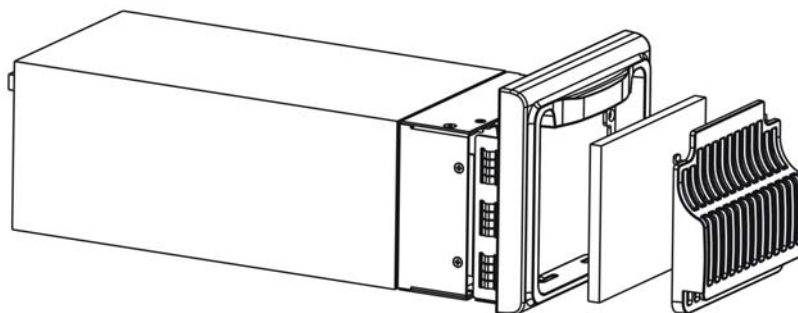

Fig 2-11 The installation and removal of Power module dust gauze

---

## 2.3.4 Connecting to the console

The ES4704BD provides a RJ-45 port as the local console. Users can configure the switch through a character terminal (usually a PC) with RS-232 ports. The connection procedures are listed below:

- Step 1: Find a character terminal or a PC with a RS-232 serial port.
- Step 2: Connect the RS-232 serial port of character terminal to the configuration port of the switch, ensuring at least one of them is powered down.

---

### Notice

Upon connection, please verify the sign above the port to avoid using the wrong port.

---

#### Connecting to the Management Port

The EM4704BD-M12GX-SFP , EM4704BD-M24TX4GC and EM4710BD-agent provides a RJ-45 (female) Ethernet port. Users can connect to this administration port through a backend host with Ethernet interface for program loading, or use this port to connect to remote devices (e.g., an administrative workstation) for remote administration.

The connection procedure is listed below:

- Connecting to a back-end PC
  - Step 1: Find a PC with Ethernet Interface
  - Step 2: Connect the PC to the RJ-45 Ethernet port of the switch with a twisted-pair crossover cable
- Remote Administration of the device
  - Step 1: Connect the administrative Ethernet port in the main controlling board to a Hub with a standard network cable
  - Step 2: Connect the Hub to an administrative workstation in the local area network.
- Or,
  - Step 1: Connect the administrative Ethernet port in the main controlling board to a router with a crossover network cable
  - Step 2: Connect the router to an administrative workstation in the wide area network.

## 2.3.5 SFP transceiver installation

In the ES4704BD, each line card with a 1000BASE fiber interface provides several SFP 1000BASE transceiver slots.

The procedure for installing the SFP 1000BASE fiber transceiver is shown below:

- Step 1: Put on a ESD wrist strap (or antistatic gloves)
- Step 2: Insert the SFP transceiver onto the guide rail inside the 1000BASE fiber interface line card Do not put the SFP transceiver up-side-down.
- Step 3: Push the SFP transceiver along the guide rail gently until you feel the transceiver

---

snap into place at the bottom of the line card.

Note: the SFP 1000BASE fiber transceiver is hot swappable.

---

 **Notice**

Do not stare directly at the 2 fiber bore in the SFP 1000Base fiber transceiver when the switch is in operation. The laser may hurt your eyes.

---

## 2.3.6 XENPAK transceiver installation

In the ES4704BD, Each EM4700BD-2XG-XENPAK line card provides 2 XENPAK 10GB fiber transceiver slots. The procedure for installing the XENPAK 10GB fiber transceiver is shown below:

- Step 1: Put on an ESD wrist strap (or antistatic gloves)
- Step 2: Insert the XENPAK transceiver onto the guide rail inside the 10GB line card. Do not put the XENPAK transceiver up-side-down.
- Step 3: Push the XENPAK transceiver along the guide rail gently until it comes into contact with the front panel of the 10GB line card.
- Step 4: Tighten (clockwise) the panel fasteners in the front of XENPAK transceiver until fastened to the front panel of the 10GB line card.

Note: the XENPAK 10GB fiber transceiver is hot swappable

---

 **Notice**

Do not stare directly at the 2 fiber bore in the XENPAK 10GB fiber transceiver when the switch is in operation. The laser may hurt your eyes.

---

## 2.3.7 Copper Cable/Fiber Cable Connection

### **Ethernet cable connection:**

- Step 1: Insert one end of the Ethernet cable into the RJ-45 Ethernet port in the switch copper cable line card
- Step 2: Insert the other end of the Ethernet cable into the RJ-45 Ethernet port of the other device
- Step 3: Check all status indicators for the corresponding ports, a lighted LINK indicates the link has been established, otherwise the link is not ready and the cable should be examined

---

 **Notice**

Upon connection, please verify the sign above the port to avoid use of other ports, which might damage to the modules or the switch.

---

---

**The connection procedure for fibers are listed below:**

Step 1: Remove the protective dust plug from the SFP/XENPAK fiber transceiver bore; take out the fiber cable and remove the protective cap from one end of the fiber cable. Keep the fiber end clean and neat.

Step 2: Immediately attach the end of the fiber cable to the SFP/XENPAK transceiver, and the other end to the transceiver of the corresponding device. Note: Upon connection, the SFP/XENPAK transceiver's TX port should be connected to the RX port of the corresponding device, and vice versa.

Step 3: Check the fiber port status indicator, a lighted LINK indicates that the link has been established, otherwise the link is not ready and should be examined.

---

 **Notice**

Upon connection, please verify the sign above the port to avoid using other ports, which might damage the transceiver or the other ports.

When connecting the other device through fiber cable to the switch, the output power of the fiber must not exceed the maximum received power of the corresponding modules, otherwise, it will damage the switch. Do not stare at the fiber bore when the switch is in operation to avoid harm.

---

## 2.3.8 Power supply connection

Connection procedures for the AC power supply module are described below:

Step 1: Insert one end of electrical line into the power supply socket and another end into the corresponding socket of the switch; when connecting electrical lines, it shall be confirmed that the power supply modules are power off.

Step 2: It shall be examined whether or not the fan on the power supply module operates normally. If the fan fails to operate, please examine whether the power supply socket is power on and whether the power supply module are inserted and locked properly.

Step 3: Turn on the power supply modules (if there are two power supply modules, both of them shall be turned on.), and examine whether or not the indicator of the indicator of the front panel is normal. If the OUTPUT GOOD indicator fails to be on, please turn off the power supply without delay and examine the status of power supply and each inserting plate.

---

 **Notice**

---

If the Power OK indicator does not illuminate after repeating the above steps, please contact the dealer. Do not open the switch chassis by yourself. Please contact the dealer in the case of any failure.

---

## Chapter 3 Caractéristiques du système ES4700BD

Les caractéristiques du système de switch ES4704BD sont décrites dans le tableau ci-dessous.

Caractéristiques du système ES4704BD(1)

SDRAM	128MB
FLASH	32MB
Indicateur d'état:	Port: Trafic, LIEN Général : Indicateurs d'état d'alimentation, d'état système, d'échange à chaud
Poids	30KG (Poids maxi de la configuration complète)
Dimensions physiques	440mm x 266mm x 421mm (L x H x P)
Humidité relative	10% ~ 90% sans condensation
Températures de fonctionnement	0°C ~ 40°C
Alimentations	Tension nominale d'entrée AC: 90 ~ 264 VAC, 50 ~ 60Hz (prise en charge 1+1 secours redondant de modules d'alimentation)
Consommation électrique	≅ 400 W
Mode de transfert	Store-and-forward (Stocke et transfère)

Caractéristiques du système ES4704BD(2)

Propriété	Spécification
Configuration de base	4 slots
Échange à chaud	Oui
Conception résistante à la panne	Partie noyau redondante échangeable à chaud
	Alimentations redondantes échangeables à chaud

## Caractéristiques du système ES4710BD

### Caractéristiques du système ES4710BD

SDRAM	128MB
FLASH	32MB
Indicateur d'état:	Port: Trafic, LIEN Général: Indicateurs d'état d'alimentation, d'état système, d'échange à chaud

Poids	65KG (Poids maxi de la configuration complète)
Dimensions physiques	436mm x 797mm x 478mm (L x H x P)
Humidité relative	10% ~ 90% sans condensation
Températures de fonctionnement	0°C ~ 40°C
Alimentations	Tension nominale d'entrée AC: 90~ 264 VAC, 50 ~ 60 Hz (prise en charge 2+1 secours redondant de modules d'alimentation)
Consommation électrique	≅ 1200 W
Mode de transfert	Store-and-forward (Stocke et transfère)

Les caractéristiques du système de switch ES4710BD sont décrites dans le tableau ci-dessous.

Tableau 1.28 Caractéristiques du système ES4710BD

Propriété	Spécification
Configuration de base	10 slots
Échange à chaud	Oui
Conception résistante à la panne	Partie noyau redondante échangeable à chaud
	Alimentations redondantes échangeables à chaud

Pendant l'installation du switch ES4704BD, veuillez suivre les consignes de sécurité

listées ci-dessous :

### Consignes de base



- 
1. Débranchez les alimentations du châssis avant de démonter ou de déplacer le switch.
  2. Installez le switch dans une zone propre, en vous assurant des bonnes conditions de température et d'humidité.
  3. Conservez les accessoires du dispositif dans un lieu sûr.
  4. Lorsque vous manipulez des modules, faites le toujours par le bord, évitez tout contact avec les composants intégrés et les circuits imprimés.
  5. Évitez les dégâts liés aux décharges électrostatiques sur les composants intégrés et les circuits imprimés.
  6. Conservez les outils de maintenance dans un lieu sûr.
  7. Ne portez pas de vêtements amples qui pourraient s'accrocher aux dispositifs, et souvenez-vous de serrer cravates et écharpes, et de rouler vos manches.
  8. Si l'environnement peut être nuisible pour les yeux, assurez-vous de porter une paire de lunettes de protection.
  9. N'effectuez aucune opération qui pourrait conduire à des blessures corporelles ou à des dégâts au dispositif.
  10. Lorsque vous nettoyez le switch, n'utilisez pas de chiffon humide pour essuyer le switch et ne le lavez jamais avec du liquide.

#### **Avertissement de sécurité**

1. Des avertissements de sécurité apparaissent au fil de cette publication, se référant à des opérations **qui peuvent vous blesser si elles sont mal réalisées**.
2. Lisez entièrement les instructions d'installation avant d'utiliser le système.
3. Seul du personnel formé et qualifié ne doit être autorisé à installer, remplacer ou maintenir le switch.
4. Débranchez les alimentations du châssis avant de démonter ou de déplacer le switch.
5. La configuration finale du produit doit se soumettre aux codes légaux nationaux.

#### **Consignes de sécurité pour le travail sur des lignes sous tension**

1. Avant de travailler sur un équipement qui est connecté à des lignes sous tension, enlevez tout bijou (y compris bagues, collier, montres et bracelets).
2. Les objets métalliques provoquent des court-circuits et endommagent le dispositif lorsqu'ils entrent en contact avec des éléments sous tension et la masse.
3. Une mauvaise connexion entre le dispositif et les prises secteurs peut être dangereuse.
4. Seul du personnel formé et qualifié ne doit être autorisé à utiliser ou maintenir le dispositif.
5. Lisez toutes les consignes d'installation avant de mettre le système sous tension.

#### **Remarque**

! Faites attention aux dangers potentiels, par ex les sols humides, les

---

lignes sous tension non reliées à la terre, et les lignes sous tension usagées.

- ! Faites installer un interrupteur d'urgence dans l'atelier, de sorte que l'alimentation puisse être coupée rapidement en cas d'accident.
- ! Ne travaillez pas seul si des dangers potentiels existent.
- ! En cas d'accident, prenez les mesures suivantes :
  1. Mettez le système hors tension
  2. Passez les appels d'urgence comme nécessaire
  3. Déterminez si la victime requiert un traitement immédiat et prenez les actions appropriées
  4. Si possible, envoyez quelqu'un demander de l'aide médicale ; sinon évaluez les dégâts et demandez de l'aide

## Exigences liées à l'emplacement

Le switch ES4700BD doit être utilisé en intérieur, et a les exigences suivantes:

Température ambiante: 0 ~ 40°C

Humidité: 10% ~ 90%, sans condensation

L'ES4700BD est équipé d'un ensemble ventilateur pour fournir au switch un niveau de refroidissement approprié; vous pouvez placer le switch sur un établi ou dans un rack. Assurez-vous des points suivants:

- Le rack ou l'établi doit être bien ventilé. Pour une circulation d'air suffisante, il est recommandé de monter le switch sur un rack standard de 19" avec assez d'espace. L'air conditionné est recommandé dans des zones exposées à de fortes températures l'été.
- Pour refroidir les circuits internes, le switch est livré avec des ensembles de ventilateurs internes. Pour maintenir une bonne circulation d'air à travers le châssis du switch, nous vous recommandons de maintenir une séparation minimale de 100mm entre l'entrée d'air du châssis et la sortie d'air du châssis ou tout mur. Assurez-vous que toutes les entrées et les évacuations d'air du système demeurent non obstruées. N'empilez pas d'objets lourds sur le switch.
- Assurez-vous que le rack ou l'établi est assez résistant pour supporter le poids du switch entièrement configuré.
- Assurez-vous que le rack ou l'établi est bien relié à la masse ; si l'établi n'est pas relié à la terre, il doit être placé près d'un conducteur de masse pour offrir une connexion facile à la terre pour le switch.

## Exigences en température et en humidité

Pour maximiser les performances et la durée de vie du switch, le site doit maintenir la température et l'humidité souhaités. Des conditions de forte humidité entraînent des dégradations de la résistance électrique ou même des fuites électriques, des dégradations des propriétés mécaniques et de la corrosion au niveau des composants internes. Une humidité extrêmement faible peut causer une contraction

au niveau de l'entretoise d'isolation, rendant la vis de fixation lâche. De plus, dans des environnements secs, de l'électricité statique est susceptible de se créer et de causer des dégâts aux circuits internes. Des températures extrêmes peuvent causer une baisse de la fiabilité et un vieillissement prématuré des matériaux isolants, réduisant ainsi la durée de vie en fonctionnement du switch. Les exigences recommandées en température et en humidité sont indiquées ci-dessous:

Température:		Humidité relative	
Condition long terme	Condition court terme	Condition long terme	Condition court terme
15 ~ 30°C	0 ~ 40°C	40% ~ 65%	10% ~ 90%

### Remarque

Un relevé de température et d'humidité ambiante doit être pris à 1.5m au-dessus du sol et à 0.4m devant le rack du switch, sans être couvert par le panneau de protection à l'avant et à l'arrière du rack.

Les conditions court terme se réfèrent à un maximum de 48 heures de fonctionnement en continu et un total cumulé annuel de moins de 15 jours.

Les conditions de fonctionnement exceptionnelles renvoient à des valeurs de température ambiante et d'humidité relative qui peuvent survenir pendant une panne du système d'air conditionné et les conditions de fonctionnement normal doivent être rétablies sous 5 heures.

### Poussières et particules

La poussière est nuisible au bon fonctionnement de l'ES4700BD. La poussière peut conduire à de l'adhérence électrostatique, surtout par faible humidité relative, donnant un mauvais contact pour les connecteurs métalliques ou les contacts. L'adhérence électrostatique non seulement réduit la durée de vie du produit, mais augmente également les risques d'échec de la communication. Les valeurs recommandées pour la poussière et le diamètre des particules sur le site sont indiquées ci-dessous:

Diamètre maxi (µm)	0.5	1	3	5
Densité Maxi (particules/m <sup>3</sup> )	1.4 x 10 <sup>7</sup>	7 x 10 <sup>5</sup>	2.4 x 10 <sup>5</sup>	1.3 x 10 <sup>5</sup>

De plus, le sel, l'acide et les sulfates de l'air sont nuisibles au switch. De tels gaz nuisibles aggravent la corrosion métallique et le vieillissement de certaines pièces. Le site choisi doit éviter les gaz nuisibles tels que SO<sub>2</sub>, H<sub>2</sub>S, NO<sub>2</sub>, NH<sub>3</sub>, et Cl<sub>2</sub>, etc. Le tableau ci-dessous détaille les valeurs seuils.

Gaz	Moyenne (mg/m <sup>3</sup> )	Maxi (mg/m <sup>3</sup> )
-----	------------------------------	---------------------------

SO <sub>2</sub>	0.2	1.5
H <sub>2</sub> S	0.006	0.03
NO <sub>2</sub>	0.01	0.15
NH <sub>3</sub>	0.05	0.15
Cl <sub>2</sub>	0.01	0.3

## Éviter les dégâts par décharge électrostatique

Les décharges électrostatiques peut endommager les circuits internes, et le même le switch entier. Suivez ces consignes pour éviter les dégâts ESD:

1. Assurez une bonne mise à la terre du dispositif
2. Effectuez un nettoyage régulier pour diminuer la poussière
3. Maintenez une température et une humidité appropriées
4. Portez toujours un bracelet ESD et une tenue antistatique lorsque vous êtes en contact avec les circuits imprimés

## Exigences anti-interférences

Toutes les sources d'interférence, qu'elles viennent du dispositif/système lui même ou de son environnement extérieur, affectent le fonctionnement de différentes façons, comme le couplage capacitif, le couplage inductif, les radiations électromagnétiques, l'impédance commune (y compris le système de mise à la masse) et les câbles/lignes (câbles d'alimentation, lignes de signaux, et lignes de sortie). Il faut noter les points suivants:

1. Il faut prendre des précautions pour éviter les interruptions de la source d'alimentation
2. Le système doit avoir sa propre mise à la terre, plutôt que de partager la terre avant des équipements ou de dispositifs de protection contre la foudre
3. Restez à l'écart des transmetteurs radio de forte puissance, des transmetteurs radar, des dispositifs à circuit fort et de haute fréquence
4. Fournissez une protection électromagnétique si nécessaire

## Configuration rack

Les dimensions de l'ES4704BD sont conçues pour être monté dans un rack standard de 6", ces dimensions étant de 440mm x 266mm x 421mm (L x H x P). Les dimensions de l'ES4710BD sont conçues pour être monté dans un rack standard de 19", ces dimensions étant de 436mm x 797mm x 478mm (L x H x P). Veuillez assurer une bonne ventilation au rack.

- Chaque dispositif du rack génère de la chaleur en fonctionnement, des ventilateurs et des ouïes sont donc prévus pour les racks fermés, et les dispositifs doivent être empilés de façon étroite.
- Lors du montage de dispositifs en rack ouvert, il faut faire attention à éviter que le

---

châssis du rack n'obstrue pas les ouvertures de ventilation du switch. Assurez-vous de vérifier le positionnement du switch après installation pour éviter les problèmes sus-mentionnés.

#### **Remarque**

Si aucun rack standard de 19" n'est disponible, l'ES4700BD peut être placé sur un bureau dégagé et de niveau, en laissant un dégagement de 100mm autour du switch pour la ventilation, et en ne plaçant rien au dessus du switch.

## **Exigences relatives à l'alimentation**

L'ES4704BD est conçu pour utiliser des alimentations électriques à découpage modulaires, prenant en charge 1 + 1 secours redondant de modules d'alimentation. La spécification électrique en entrée est indiquée ci-dessous:

Tension nominale d'entrée

AC: 90 ~ 264 VAC, 50 ~ 60Hz

Consommation électrique totale:  $\leq 400W$

L'ES4710BD est conçu pour utiliser des alimentations électriques à découpage modulaires, prenant en charge 2 + 1 secours redondant de modules d'alimentation. La spécification électrique en entrée est indiquée ci-dessous:

Tension nominale d'entrée

AC: 90 ~ 264 VAC, 50 ~ 60Hz

Consommation électrique totale:  $\leq 1200W$

Avant d'installer les modules d'alimentation, veuillez vérifier l'entrée électrique pour vous assurer d'une bonne mise à la masse de votre système d'alimentation électrique. La source d'entrée pour le switch doit être fiable et sûre, un adaptateur de tension peut être utilisé si nécessaire. Le système de protection circuit du bâtiment doit comprendre un fusible ou un coupe-circuit au plus de 240V, 10A. Il est recommandé d'utiliser une UPS pour une alimentation électrique plus fiable.

#### **Remarque**

Une mauvaise masse sur le système d'alimentation électrique, des fluctuations extrêmes de la source d'entrée, et des transitoires (ou pics) peuvent donner un taux d'erreur plus important ou même des dégâts matériels.

## **Préparation pour l'installation**

Après avoir vérifié les exigences liées à l'emplacement, veuillez vérifier le contenu de l'emballage du switch et le kit d'accessoires. (Si vous êtes inquiet qu'un élément soit manquant ou qu'un élément incorrect ait été fourni, veuillez contacter votre revendeur aussi vite que possible.)

---

## Vérification du matériel et des accessoires du switch

Après avoir vérifié les exigences liées à l'emplacement, vous pouvez à présent déballer le carton d'expédition pour vérifier la configuration du switch et le contenu du kit d'accessoires.

Une configuration de base de l'ES4704BD doit comprendre ce qui suit :

ITEM N°.	Nom de la pièce	Numéro	Mémo
1	Switch Ethernet ES4704BD	1	
2	Câble AC	3	
3	Câble port série	1	
4	Cordon de mise à la masse	1	
5	Porte châssis	2	
6	Vis support	8	
7	Vis rack	8	
8	CD Manuel	1	
9	Certificat de qualification	1	
10	Carte de garantie	1	

Une configuration de base de l'ES4710BD doit comprendre ce qui suit :

ITEM N°.	Nom de la pièce	Numéro	Mémo
1	Switch Ethernet ES4710BD	1	
2	Câble AC	3	
3	Câble port série	1	
4	Cordon de mise à la masse	1	
5	Porte châssis	2	
6	Vis support	12	
8	CD Manuel	1	
9	Certificat de qualification	1	
10	Carte de garantie	1	

Remarque: la liste ci-dessus est sujette à modification sans préavis, veuillez utiliser le

bordereau d'expédition livré avec le switch comme check-list.

---

## Montage en rack du ES4700BD

- **Remarque:**

Avant de monter l'ES4700BD dans le rack, vérifiez que les positions de montage du rack sont correctes. Le pré positionnement des points de montage peut résulter dans un mauvais espacement entre la face avant du switch et la porte avant du rack peut s'avérer impossible de se fermer une fois les câbles et les fibres connectés. Veuillez conserver un espacement de 10 mm entre la face avant du switch et la porte avant du rack.

Vérifiez ceci avant l'installation : le rack est positionné de façon stable; tous les modules à l'intérieur du châssis sont complètement installés ; aucune obstruction n'est présente à l'intérieur ou autour du rack; le switch est situé près du rack pour faciliter l'installation.

- **Les étapes de l'installation**

Étape1 : Attachez les 2 supports sur l'ES4700BD avec les vis fournies dans le kit d'accessoires.

Assurez-vous d'attacher les supports dans le bon sens, sinon le switch ne pourra pas se monter dans un rack standard.

Notez que les supports ne supportent aucun poids. Ils servent à fixer le switch. L'étagère de montage ou les rails coulissant (boulonnés sur le rack) supportent eux le switch.

La figure ci-dessous montre les étapes de montage des supports :

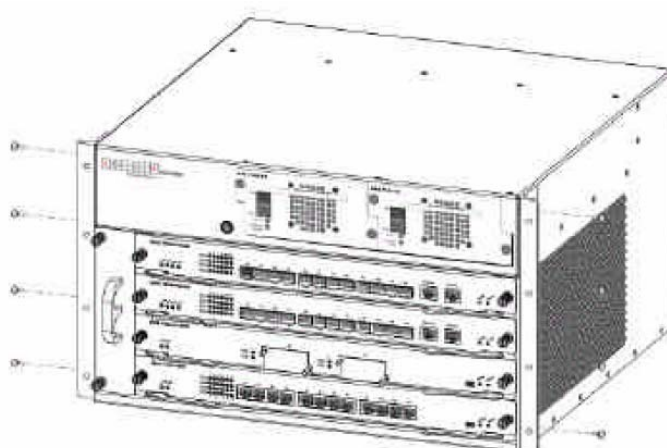

Installation des supports du switch ES4704BD

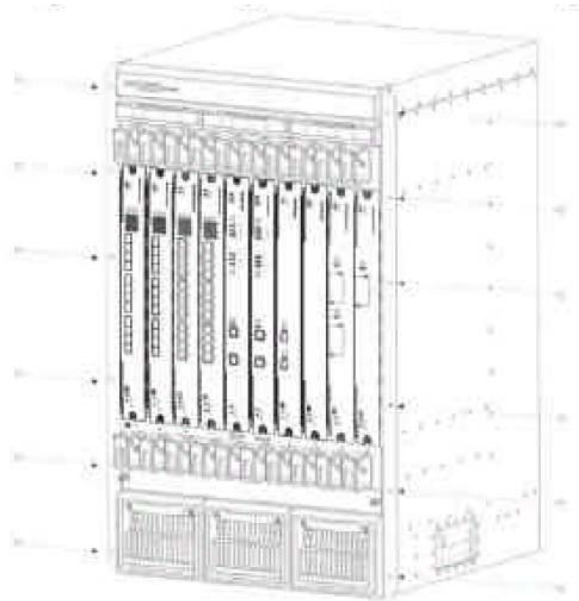

### Installation des supports du switch ES4710BD

Étape 2 : Mettez le switch monté sur supports doucement dans le rack standard de 6”.

En raison de la taille et du poids d'un ES4700BD, 2 personnes sont nécessaires pour terminer l'installation. Une personne se tenant de chaque côté du châssis, saisissez la poignée du châssis par le bas du panneau avec une main, et utilisez l'autre main près du haut du châssis pour garder l'équilibre. Soulevez lentement le châssis ensemble et amenez le sur le rack. Soulevez l'ES4700BD jusqu'à une position un peu plus haute que l'étagère de montage ou les rails de montage, en reposant le châssis sur l'étagère/rails, puis faites glisser avec précaution le châssis dans le rack. Assurez-vous d'aligner les supports avec les trous de montage dans la bonne colonne.

Étape 3 : Attachez l'ES4700BD au rack avec la vis fournie.

Boulonnez les supports sur les trous correspondants de la colonne du rack avec les vis fournies. Assurez-vous de serrer doucement les vis. L'ES4700BD doit à présent être bien attaché au rack d'équipements.

La procédure est décrite ci-dessous :



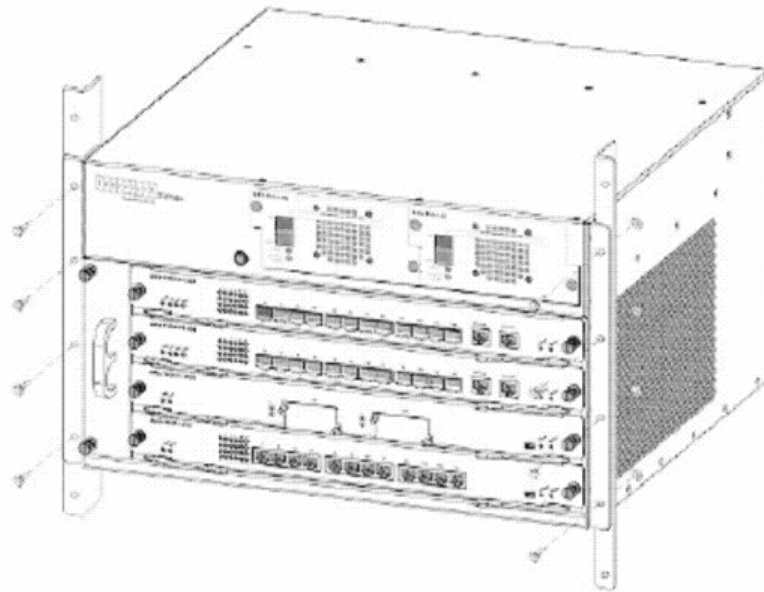

Montage en rack du ES4704BD

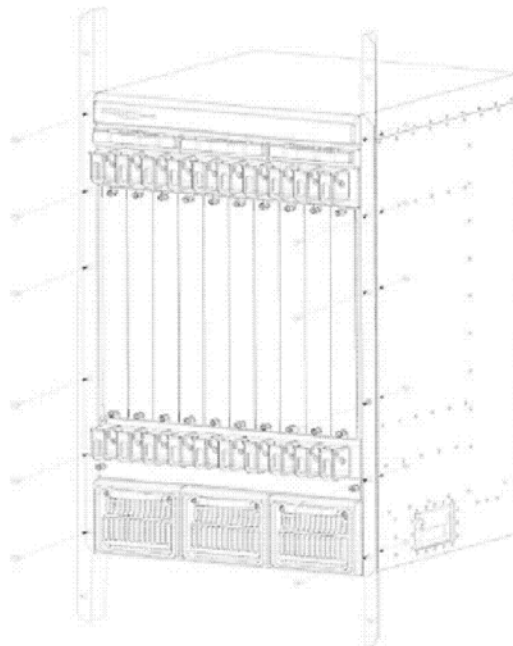

Montage en rack du ES4710BD

## Porter un bracelet antistatique

Il faut porter un bracelet antistatique pendant l'installation du switch. Pour éviter tout dégât sur le dispositif, évitez tout contact entre les circuits imprimés et vos vêtements. Évitez tout contact du corps avec les composants des circuits imprimés dans la mesure du possible.

Pour porter un bracelet antistatique:

Étape 1: Placez votre main dans le bracelet antistatique

---

Étape 2: Serrez le fermoir et assurez-vous qu'il soit en contact maximal avec la peau  
Étape 3: Insérez l'extrémité équipement du bracelet dans la prise antistatique (indiquée par un symbole ESD) sur le panneau avant du switch

## Mise à la masse du switch

Un bon système de mise à la masse est la base pour un fonctionnement sûr et sans problème de l'ES4700BD, et une excellente façon d'éviter la foudre et l'interface de résistance. Veuillez suivre les instructions de la spécification de mise à la masse du switch, vérifiez l'état de la masse du site d'installation et assurez une bonne mise à la masse.

- **Mise à la masse correcte**

Lorsque vous utilisez une source électrique AC, le dispositif doit être mis à la masse avec les câbles vert et jaune, sinon, des électrocutions peuvent survenir lorsque la résistance d'isolation entre l'alimentation électrique interne et le châssis se dégrade.

- **Mise à la masse pour protection contre la foudre**

Le système de protection contre la foudre est un système indépendant consistant en un paratonnerre, un conducteur et un lien de connexion avec le système de mise à la masse. Le système de mise à la masse est en général partagé avec la mise à la masse de la référence électrique et le câble de mise à la masse jaune et vert. La mise à la masse pour protéger contre la foudre est une exigence du bâtiment, pas une exigence spécifique au switch.

- **Mise à la masse pour conformité électromagnétique**

Ceci renvoie à la mise à la masse pour se conformer aux exigences de compatibilité électromagnétique, y compris la mise à la masse du blindage, les filtres de masse, le bruit et le contrôle des interférences et les références de niveau. Les exigences de mise à la masse globales sont la somme totale de ce qui précède. La valeur de résistance à la masse doit être inférieure à 1 ohm.

L'ES4700BD offre une mise à la masse du châssis en bas et à l'arrière du châssis, marquée "GND". La mise à la masse de protection du châssis doit être correctement branchée au connecteur de mise à la masse du rack.

Les procédures de câblage de la masse sont listées ci-dessous :

Étape 1: enlevez les écrous des piquets de masse à l'arrière du châssis

Étape 2: chaînez une extrémité du câble jaune et vert de mise à la masse sur les piquets de masse

Étape 3: attachez l'écrou du piquet de masse et serrez bien

Étape 4: attachez l'autre extrémité du câble de mise à la masse au connecteur de mise à la masse du rack

Remarque :

- Le câble de mise à la masse doit être réalisé dans un bon conducteur, et le diamètre doit être déterminé par le courant maximum possible pouvant traverser.
- Le câblage du conducteur à nu est interdit.
- Valeur de résistance de masse : la valeur de résistance à la masse combinée

---

doit être inférieure à 1 ohm.

## Installation de la carte et du module

L'ES4700BD est un dispositif de montage en rack, diverses cartes et modules sont disponibles.

Configuration de base: châssis, modules d'alimentation électrique (optionnel 1 + 1 redondant), back plane du système, plateau du ventilateur, gaze à poussières, boîte de distribution. Les pièces ci-dessus ont été montées à l'expédition, veuillez vérifier qu'elles sont bien fixées avant installation.

## Enlever et installer les cartes

La procédure d'installation est la même pour toutes les cartes, comme décrite ci-dessous:

- Étape 1: Éteignez le switch (L'échange à chaud est pris en charge par les cartes optionnelles pour le switch. Cependant, pour plus de commodité, il est recommandé d'éteindre le switch avant d'installer les cartes, si aucun module du switch ne tourne.)
- Étape 2: Assurez une bonne mise à la masse du switch
- Étape 3: Mettez un bracelet antistatique avant de toucher le circuit du switch, et assurez-vous que le bracelet antistatique est fermement attaché au connecteur ESD du panneau avant du switch.
- Étape 4: Desserrez la plaque arrière de verrouillage des fixations du panneau dans le sens inverse des aiguilles d'une montre et enlevez la plaque arrière.
- Étape 5: Insérez le module optionnel dans le slot, vous pouvez utiliser la poignée métallique de la plaque avant du module pour assurer un bon contact. Puis verrouillez le module avec les fixations du panneau sur la face avant.

## Enlever et installer les modules d'alimentation

### ES4710BD

L'ES4710BD emploie une combinaison de modules d'alimentation 2 + 1 redondant, les trois modules fonctionnant en utilisation normale. En cas de panne d'un module, il peut être remplacé pendant que le système fonctionne sans risque électrique ou de dégât au système. Les procédures sont fournies ci-dessous:

- Étape 1: Desserrez les 2 fixations de panneau sur le panneau avant du module d'alimentation électrique à remplacer, en faisant tourner le tournevis dans le sens inverse des aiguilles d'une montre
- Étape 2: Tenez la poignée en haut du panneau avant du module d'alimentation électrique, et tirez fermement mais en douceur sur le module d'alimentation électrique
- Étape 3: Utilisez un nouveau module d'alimentation électrique et remplacez celui

---

qui est en panne

Étape 4: Serrez les fixations du panneau sur la face avant

Étape 5: Un remplacement réussi est indiqué par un témoin vert Power OK allumé et par un témoin de panne jaune éteint.

L'installation d'un module d'alimentation électrique est décrite ci-dessous:

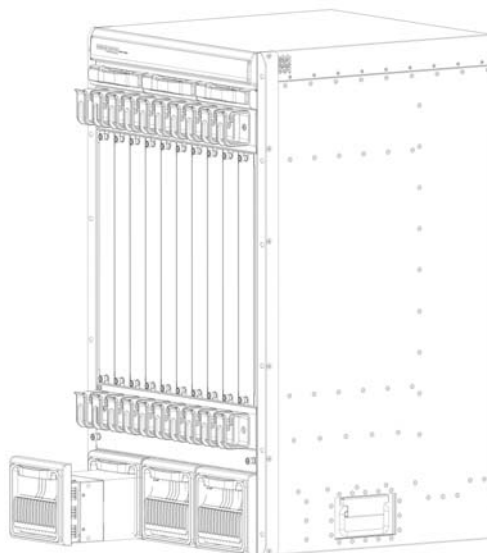

L'installation et le démontage des modules d'alimentation électrique de l'ES4710BD

- Nettoyage du gaz à poussières du module d'alimentation :

Des gazes à poussières de module d'alimentation électrique sont installées sur les panneaux avant des modules d'alimentation électrique EM4710BD-AC et, et elles peuvent être enlevées et installées facilement. Elles peuvent éviter que de gros débris ou des particules dans l'air ne soient ingérées par le module d'alimentation électrique. Veuillez effectuer un nettoyage de façon régulière selon les conditions du site.
- En tirant sur le panneau avant de la gaze à poussières inférieure, retirez la gaze à poussières et le panneau avant
- Nettoyez la gaze à poussières avec une brosse (n'utilisez jamais de liquide pour laver)
- Réinsérez la gaze à poussières à sa position initiale dans module d'alimentation électrique
- Enfoncez la gaze à poussières et le panneau avant dans le module électrique
- Appuyez sur le panneau avant de la gaze à poussières inférieure et verrouillez-le

L'installation et la dépose de la gaze à poussières sont décrites ci-dessous:

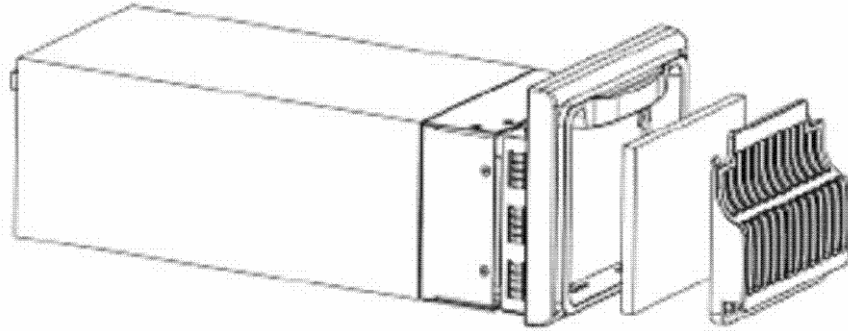

## Connexion à la console

L'ES4704BD comprend un port RJ-45 comme console locale. L'utilisateur peut configurer le switch via un terminal texte (en général un PC) avec ports RS-232. Les procédures de connexion sont listées ci-dessous :

Étape 1: Trouvez un terminal texte ou un PC avec un port série RS-232.

Étape 2: Branchez le port série RS-232 du terminal texte sur le port de configuration du switch, en vous assurant qu'au moins un d'eux est éteint.

### Remarque

A la connexion, veuillez vérifier le signe ci-dessus pour éviter d'utiliser un mauvais port.